

Test report No.: 22-00037-CP-PR-01
Manufacturer: OKB Sp. z o.o., Poland
Type: OB



Test report
No.: 22-00037-CP-PRG-01

Test of a type of a vehicle
with regard to ECE Regulation No. **14.00**
taking into consideration amendment No. **14.09, Supplement 2**
Approval subject: **Strength of safety belt anchorages**

Approval status	
Granting of a type approval	N/A
Extension/correction to type approval no.	N/A

Test report only.

Test report No.: 22-00037-CP-PR-01
Manufacturer: OKB Sp. z o.o., Poland
Type: OB



0. Reasons of extension:

- 1. Addition of new vehicles types**
- 2. Addition of new drawings**
- 3. Editorial changes**

I. General

Make: MOBIFRAME
Type: OB
Category of vehicle: M1, M2, N1, N2
Type of bodywork using the codes set out in Part C of Annex II of Directive 2007/46/EC or in Part C of Annex I to Regulation (EU) 2018/858: AC, AF, BB, BA, BX, CA, SA, SH
Name and address of manufacturer: OKB Sp. z o.o.
Szkolna 9, Bukowiec
95-006 Brójce
Poland
Reference number of information folder: MOBIFRAME/02/2022-01
Date of issue of information folder: **26.06.2023**

Test report No.: 22-00037-CP-PR-01
Manufacturer: OKB Sp. z o.o., Poland
Type: OB



II. Test results

Refer to the Annex

III. Enclosures

Information Folder

IV. Statement of conformity

The mentioned information folder and the type described therein are in accordance with the test basis mentioned above. The worst-case was selected in accordance with document "Requirements for Test Reports (AS-PB-T-02)".

The test report may be reproduced and published in full and by the client only. It can be reproduced partially with the written permission of the test laboratory only.

TÜV SÜD Auto Service GmbH is designated as Technical Service by:

Genehmigungsbehörde/ Approval authority	Land/ Country	Registriernummer/ Registration number
Kraftfahrt-Bundesamt (KBA)	Deutschland/ Germany	KBA-P 00100-10
Vehicle Certification Agency (VCA)	Vereinigtes Königreich/ United Kingdom	VCA-TS-006
Approval Authority of the Netherlands (RDW)	Niederlande/ The Netherlands	RDWT-082-xx
National Standards Authority of Ireland (NSAI)	Irland/ Ireland	Technical Service Number: 49
Vehicle Safety Certification Center (VSCC)	Taiwan/ Taiwan	DE04-06-2
Société Nationale de Certification et d'Homologation s.à r.l. (SNCH)	Luxemburg/ Luxembourg	13/B(g)
Swedish Transport Agency (STA)	Schweden/ Sweden	TT 0024

Munich, 30.06.2023

Ing. Vít Bursík

Authorized signatory



Test report No.:
Manufacturer:
Type:

22-00037-CP-PR-01
OKB Sp. z o.o., Poland
OB



Annex

Test report

1. Technical data of the test sample

UN Regulation No. 14.09

- 1.1. Test object: Bodyworks of vehicles for which given swivel variant is intended (see section 3 of test report) and MOBIFRAME OB-? Swivels mounted with original base vehicle seats and original seatbelts.
For details see manufacturer's information folder.
- 1.1.1. Location and arrangement:
Seats
Number of seating positions: 1 or 2 (driver and/or passenger)
Location and arrangement: 1st row of seats (in driver's cab)
- 1.1.2. Variant/Version: OB-?
"?" – dedicated for the vehicles:
T – Ford Transit, Ford Transit Custom
S – Mercedes-Benz Sprinter 906, Volkswagen Crafter 2E???, Freightliner/Dodge Sprinter
V – Mercedes-Benz Sprinter 907, Sprinter 910, Freightliner/Dodge Sprinter
C – Volkswagen Crafter, MAN TGE
A – Volkswagen T5, Volkswagen T6
F – Fiat Ducato, Peugeot Boxer, Citroen Jumper, Opel/Vauxhall Movano, RAM ProMaster
O – Renault Trafic, Opel/Vauxhall Vivaro, Nissan NV300, Fiat Talento
M – Maxus eDeliver 9, Deliver 9
J – Citroen Jumpy, Peugeot Expert, Fiat Scudo, Toyota ProAce, Opel/Vauxhall Vivaro
- Swivels can also be mounted in electric version of the vehicles.**

Test report No.: 22-00037-CP-PR-01
 Manufacturer: OKB Sp. z o.o., Poland
 Type: OB



1.1.3. Name and address of manufacturer: OKB Sp. z o.o.
 Szkolna 9, Bukowiec
 95-006 Brójce
 Poland

1.1.4. Mass of original driver's/passenger seat and base with additional swivel MOBIFRAME
 OB – 70 kg (allowable mass in the heaviest configuration)

Vehicle(-s)	Maximum mass of original driver's/passenger seat with base	Maximum mass of additional swivel (mounted between original driver's/passenger seat and seat base)
Ford Transit Ford Transit Custom	39 kg	15 kg
MB Sprinter (906) Volkswagen Crafter (2E???) MB Sprinter (907) MB Sprinter (910) Freightliner/Dodge Sprinter	40 kg	
Volkswagen Crafter, MAN TGE	49,8 kg	
Volkswagen T5 Volkswagen T6	40 kg	
Fiat Ducato, Citroën Jumper Peugeot Boxer, Opel/Vauxhall Movano, Ram ProMaster	40,7 kg	
Renault Trafic, Opel/Vauxhall Vivaro Nissan NV300, Fiat Talento	38,4 kg	
Maxus eDeliver 9 Maxus Deliver 9	42,5 kg	
Citroen Jumpy Peugeot Expert Fiat Scudo Toyota ProAce Opel/Vauxhall Vivaro	40,7 kg	

For details see manufacturer's information folder.

Note: Testing laboratory does not bear any responsibility for possibly incorrect values of masses, and dimensions provided by the manufacturer and for test results found out based on these values.

Test report No.:
 Manufacturer:
 Type:

22-00037-CP-PR-01
 OKB Sp. z o.o., Poland
 OB



1.1.5. Table of vehicles types for which are test results valid:

Manufacturer	Commercial description / Type	Wheelbase
Daimler / Mercedes-Benz	Sprinter (906, 907)	3250, 3665, 4325
	Sprinter, e-Sprinter (910)	3259, 3924
VW	Crafter (2E_, 3E_)	3250, 3665, 4325
	Crafter e-Crafter (SYN_, SYM_ e.g. SYN1E, SYM1E , SYN2E, SYM2E , SYN2Z, SYM2Z)	3640, 4490
	T5 (7H_, 7E_, 7J_)	3000, 3400
	T6, T6.1, e-Transporter (7H_, 7E_, 7J_)	3000, 3400
Citroen	Jumper, e-Jumper (Y, CY)	3000, 3450, 4035
	Jumpy, e-Jumpy (G9/X, V) (SpaceTourer, E-SpaceTourer (V))	2925, 3275
Peugeot	Boxer (Y)	3000, 3450, 4035
	Expert, e-Expert (G9/X, V) (Traveller, e-Traveller (V))	2925, 3275
Fiat	Ducato, e-Ducato (250)	3000, 3450, 4035
	Talento (FJL, FFL)	3098, 3498
	Scudo (2022-...)	2925, 3275
Opel/Vauxhall	Movano, Movano-e (Y)	3000, 3450, 4035
	Vivaro (F7)	3098, 3498
	Vivaro, Vivaro-e, Vivaro e-Kombi, Vivaro Life (V) (Zafira Life)	2925, 3275
Renault	Trafic (FL, EL , L)	3098, 3498
	Trafic 2014 (JL, L)	3098, 3498
Ford	Transit (FC_)	3300, 3750, 3954
	Transit Custom (FA_, FC_)	2933, 3300
Nissan	NV300, Primastar	3098, 3498
MAN	TGE (SYN_, SYM_ e.g. SYN1E, SYM1E , SYN2E, SYM2E , SYN2Z, SYM2Z)	3640, 4490
Freightliner/Dodge	Sprinter	3250, 3665, 4325
RAM	ProMaster	3000, 3450, 4035
MAXUS	eDeliver 9, Deliver 9	3000, 3366, 3760
Toyota	Pro Ace, Pro Ace Verso, Pro Ace Electric (X, V)	2925, 3275

1.1.6. Table: Seats and seatbelts anchorages

Driver's and single passenger seat is equipped with additional swivel, which allows to lock the seat in forward-facing direction and rotate about 180 degrees. Swivel is mounted between original driver's/passenger seat and seat base. Details of seat and base construction in type approvals according to UN Reg. No. 14 and UN Reg. No. 17 presented in table below

Vehicle(-s)	Number of type approval according to (1 st stage of production)		Max mass of original driver's/passenger seat with base
	ECE R14*	ECE R17*	
Ford Transit Ford Transit Custom	E1 14R07 0732 E1 14R07 0708	E1 17R08 0889 E1 17R08 0864	39 kg
MB Sprinter (906) Volkswagen Crafter (2E???) MB Sprinter (907) MB Sprinter (910) (Freightliner/Dodge Sprinter)	E1 14R-07 0516 E1 14R-07 0524 E1 14R07 0832 E1 14R07 0832	E1 17RA-08 0530 E1 17RA-08 0546 E1 17R08 0982 E1 17R08 0982	40 kg
Volkswagen Crafter MAN TGE	E4 14R-07 0735 E4 14R 070740	E4 17RA-08 0653 E4 17RA 080659	49,8 kg
Volkswagen T5 Volkswagen T6	E4 14R 070097	E4 17RA 080112	40 kg
Fiat Ducato Citroën Jumper Peugeot Boxer Opel/Vauxhall Movano (Ram ProMaster)	E3 14R-07 3133 E3 14R07 2047 E3 14R07 2046 E3 14R07 2046	E3 17RA-08 2953 E3 17RA08 2053 E3 17RA08 2052 E3 17RA09 2052	40,7 kg
Renault Trafic Opel/Vauxhall Vivaro Nissan NV300 Fiat Talento	E2 14R07 1010 E2 14R07 1012 E2 14R07 1011 E2 14R07 15047	E2 17R08 1011 E2 17R08 1013 E2 17R08 1012 E2 17R08 15045	38,4 kg
Maxus eDeliver 9 Maxus Deliver 9	E4 14R08 0904	E4 17R08 0826	42,5 kg
Citroen Jumpy Peugeot Expert Fiat Scudo Toyota ProAce Opel/Vauxhall Vivaro	E2 14R09 15330 E2 14R09 15329 E2 14R09 15329 E2 14R09 15331 E2 14R09 15329	E2 17R09 15340 E2 17R09 15339 E2 17R09 15339 E2 17R09 15341 E2 17R09 15339	40,7 kg

*- applies also to base vehicle partial approvals with newer series of amendments then presented in the table

Swivel can be locked only in forward-facing direction when the vehicle is in motion and in forward-facing direction when the vehicle is stationary.

Anchorage points of seat base to the vehicle floor are the same both before and after swivel installation.

Test report No.: 22-00037-CP-PR-01
Manufacturer: OKB Sp. z o.o., Poland
Type: OB



2. Test conditions

2.1. UN Regulation No. 14.09

Strength test of safety belt anchorages according to UN Reg. No. 14.09

2.1.1. Instrumentation:

- Digital ballance
- Electrohydraulic test device and respective fixtures
- Force measuring chain with load cells
- Interface 1210AF
- Tape rule

2.1.2. Ambient conditions:

Normal laboratory conditions, not directly limited in Regulation

2.2. Test track or site: OKB testing laboratory, Bukowiec, Poland

3. Test results

3.1. Test procedures used (UN Reg. No.14):

Strength test of swiveling platform MOBIFRAME type OB strength of safety belt anchorages according to UN Reg. No. 14.09 concerning to strength of connection between original seat anchorages, swiveling platform and original seat.

The below mentioned test results cover all variants including the maximum mass stated in the enclosed information document (seat, seat-to-vehicle anchorages, seat arrangement).

Geometrical requirements are fulfilled, no changes from base vehicle.

3.2. First row of seats:

Forward facing seats for M1/N1 vehicles:

Test report No.: 22-00037-CP-PR-01
 Manufacturer: OKB Sp. z o.o., Poland
 Type: OB



3.2.1 MOBIFRAME type OB in FIAT Ducato
 bodywork. Mass of the seat with leg $m_s = 70$ kg.

Type of seat	Original seat Fiat Ducato
Type of leg	Original base
Bodywork (representative/specific)	Fiat Ducato
Mass of seat/seats	Max 70 kg
Required force in upper tractive device	13500 N
Max force in upper tractive device	14300 N
Required force in lower tractive device	13500 N
Max. force in lower tractive device	14100 N
Required inertia force	14000 N
Inertia force in the seat base	14450 N
Displacement of upper anchorage point	34 mm
Where was applied additional force	Lap belt
Remark: No rupture occurred.	

3.2.2 MOBIFRAME type OB-A in VW T5/T6 bodywork.
 Mass of the seat with leg $m_s = 70$ kg.

Type of seat	Original seat VW T5/T6
Type of leg	Original base
Bodywork (representative/specific)	VW T5/T6
Mass of seat/seats	Max 70 kg
Required force in upper tractive device	13500 N
Max force in upper tractive device	14300 N
Required force in lower tractive device	27500 N
Max. force in lower tractive device	29600 N
Required inertia force	-
Inertia force in the seat base	-
Displacement of upper anchorage point	18 mm
Where was applied additional force	Lap belt
Remark: No rupture occurred.	

Test report No.:
 Manufacturer:
 Type:

22-00037-CP-PR-01
 OKB Sp. z o.o., Poland
 OB



3.2.3 MOBIFRAME type OB-S and OB-V in Mercedes Sprinter 906 and 907 bodywork.
 Mass of the seats with leg $m_s = 70$ kg.

Type of seat	Original seat MB Sprinter (906)	Original seat MB Sprinter (907)
Type of leg	Original base	Original base
Bodywork (representative/specific)	MB Sprinter	
Mass of seat/seats	Max 70 kg	Max 70 kg
Required force in upper tractive device	13500 N	13500 N
Max force in upper tractive device	13780N	13420 N
Required force in lower tractive device	13500N	13500 N
Max force in lower tractive device	13500N	13690 N
Required inertia force	14000N	14000 N
Inertia force in the seat base	14380N	14380 N
Displacement of upper anchorage point	27 mm	39 mm
Where was applied additional force	CoG	CoG
Remark: No rupture occurred.		

3.2.4 MOBIFRAME type OB-T driver's and passenger's seats Ford Transit bodywork.
 Mass of the seats with leg $m_s = 70$ kg.

Type of seat	Original driver's seat Ford Transit	Original passenger's seat Ford Transit
Type of leg	Original base	Original base
Bodywork (representative/specific)	Ford Transit	
Mass of seat/seats	Max 70 kg	Max 70 kg
Required force in upper tractive device	13500 N	13500 N
Max force in upper tractive device	13720N	13540 N
Required force in lower tractive device	13500N	13500 N
Max force in lower tractive device	13640N	13560 N
Required inertia force	14000N	14000 N
Inertia force in the seat base	14310N	14210 N
Displacement of upper anchorage point	21 mm	33 mm
Where was applied additional force	CoG	CoG
Remark: No rupture occurred.		

Test report No.:
 Manufacturer:
 Type:

22-00037-CP-PR-01
 OKB Sp. z o.o., Poland
 OB



3.2.5 MOBIFRAME type OB-O driver's and passenger's seats Renault Trafic bodywork.
 Mass of the seats with leg $m_s = 70$ kg.

Type of seat	Original driver's seat Renault Trafic	Original passenger's seat Renault Trafic
Type of leg	Original base	Original base
Bodywork (representative/specific)	Renault Trafic	
Mass of seat/seats	Max 70 kg	Max 70 kg
Required force in upper tractive device	13500 N	13500 N
Max force in upper tractive device	13620N	13380 N
Required force in lower tractive device	13500N	13500 N
Max force in lower tractive device	13780N	13650 N
Required inertia force	14000N	14000 N
Inertia force in the seat base	14420N	14330 N
Displacement of upper anchorage point	29 mm	42 mm
Where was applied additional force	CoG	CoG
Remark: No rupture occurred.		

3.2.6 MOBIFRAME type OB-C driver's and passenger's seats Volkswagen Crafter/MAN TGE bodywork.
 Mass of the seats with leg $m_s = 70$ kg.

Type of seat	Original driver's seat VW Crafter	Original passenger's seat VW Crafter
Type of leg	Original base	Original base
Bodywork (representative/specific)	VW Crafter	
Mass of seat/seats	Max 70 kg	Max 70 kg
Required force in upper tractive device	13500 N	13500 N
Max force in upper tractive device	13760N	13660 N
Required force in lower tractive device	13500N	13500 N
Max force in lower tractive device	13500N	13690 N
Required inertia force	14000N	14000 N
Inertia force in the seat base	14270N	14250 N
Displacement of upper anchorage point	19 mm	28 mm
Where was applied additional force	CoG	CoG
Remark: No rupture occurred.		

Test report No.: 22-00037-CP-PR-01
 Manufacturer: OKB Sp. z o.o., Poland
 Type: OB



3.2.7 MOBIFRAME type OB-F driver's and passenger's seats Fiat Ducato.

Mass of the seats with leg $m_s = 70$ kg.

Type of seat Test No. 2023_03_20_01	Original seat Fiat Ducato
Type of leg	Original base
Bodywork (representative/specific)	Fiat Ducato
Mass of seat/seats	Max 70 kg
Required force in upper tractive device	13 500 N \pm 200 N
Max force in upper tractive device	13 900 N
Required force in lower tractive device	13 500 N \pm 200 N
Max. force in lower tractive device	13 900 N
Required force inertia	14 000 N
Inertia force in the seat base	14 300 N
Displacement of upper anchorage point	26 mm
Where was applied additional force	CoG

3.2.8 MOBIFRAME type OB-T driver's and passenger's seats Ford Transit/ Transit Custom.

Mass of the seats with leg $m_s = 70$ kg.

Type of seat Test No. 2023_04_12_01	Original seat Ford Transit/Ford Transit Custom
Type of leg	Original base
Bodywork (representative/specific)	Ford Transit
Mass of seat/seats	Max 70 kg
Required force in upper tractive device	13 500 N \pm 200 N
Max force in upper tractive device	13 700 N
Required force in lower tractive device	13 500 N \pm 200 N
Max. force in lower tractive device	13 450 N
Required force inertia	14 000 N
Inertia force in the seat base	14 200 N
Displacement of upper anchorage point	37 mm
Where was applied additional force	CoG

Test report No.: 22-00037-CP-PR-01
 Manufacturer: OKB Sp. z o.o., Poland
 Type: OB



3.2.9 MOBIFRAME type OB-M driver´s and passenger´s seats Maxus Deliver 9/ Maxus eDeliver 9.

Mass of the seats with leg $m_s = 70$ kg

Swivel	Tests on:	Fulfilling of requirements
OB-M	Maxus Deliver 9 Maxus eDeliver 9	See note. Technical Research no. 23-06-01

3.2.10. MOBIFRAME type OB-J driver´s and passenger´s seats Citroen Jumpy, Peugeot Expert, Fiat Scudo, Toyota ProAce, Opel/Vauxhall Vivaro.

Mass of the seats with leg $m_s = 70$ kg

Swivel	Tests on:	Fulfilling of requirements
OB-J	Citroen Jumpy, Peugeot Expert, Fiat Scudo, Toyota ProAce, Opel/Vauxhall Vivaro.	See note. Technical Research no. 23-06-01

UN Reg. No. 14.09: OB-M, OB-J

Technical Research no. 23-06-01

Based on the technical analysis of the laboratory and manufacturer: OKB, laboratory, Bukowiec, Poland:

Mobiframe swivels type OB are basing on the same design and structural concept. They are geometrically adapted to each base vehicle seat's fixation points arrangement. They were tested in multiple bodyworks, which are representative worst cases in terms of fixation points geometry and mass to all swivels presented in this report.

Test report No.:
Manufacturer:
Type:

22-00037-CP-PR-01
OKB Sp. z o.o., Poland
OB

3.3. Test records

3.3.1. Photos

3.2.1. MOBIFRAME type OB-F in FIAT Ducato bodywork.

Before test

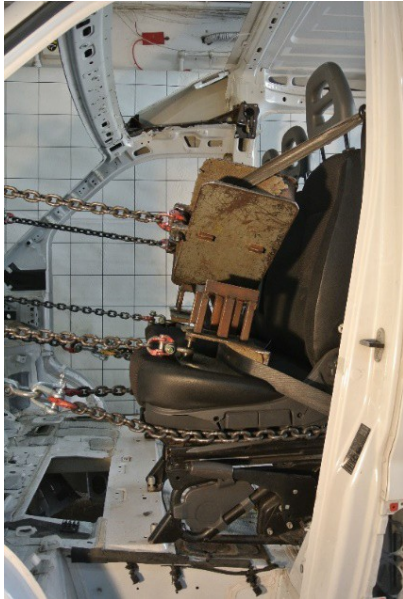

After test

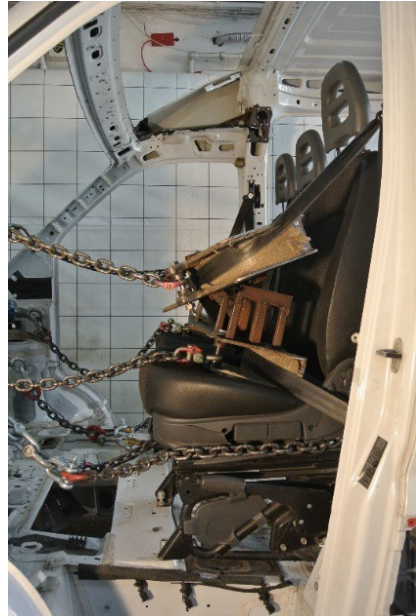

3.2.2. MOBIFRAME type OB-A in VW T5/T6 bodywork.

Before test



After test



Test report No.:
Manufacturer:
Type:

22-00037-CP-PR-01
OKB Sp. z o.o., Poland
OB



3.2.3. MOBIFRAME type OB-S and OB-V in Mercedes Sprinter 906 and 907 bodywork.

Before test



After test



3.2.4. MOBIFRAME type OB-T driver's and passenger's seats Ford Transit bodywork.

Before test



After test



Test report No.:
Manufacturer:
Type:

22-00037-CP-PR-01
OKB Sp. z o.o., Poland
OB

3.2.5. MOBIFRAME type OB-O driver's and passenger's seats Renault Trafic bodywork.

Before test



After test

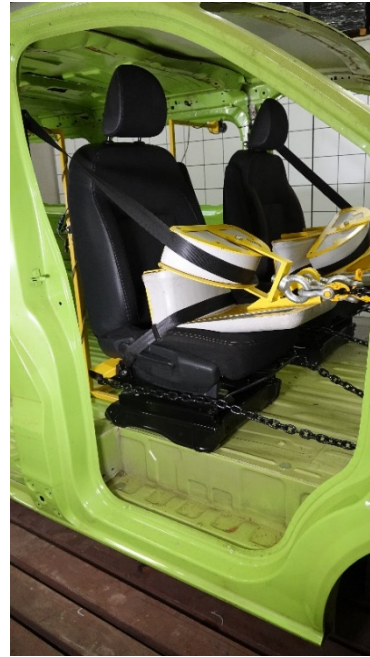

3.2.6. MOBIFRAME type OB-C driver's and passenger's seats Volkswagen Crafter/MAN TGE bodywork.

Before test



After test



Test report No.:
Manufacturer:
Type:

22-00037-CP-PR-01
OKB Sp. z o.o., Poland
OB

3.2.7. MOBIFRAME type OB-F driver's and passenger's seats Fiat Ducato.

Before test



After test



3.2.8. MOBIFRAME type OB-T driver's and passenger's seats Ford Transit/ Transit Custom.

Before test



After test



Test report No.: 22-00037-CP-PR-01
 Manufacturer: OKB Sp. z o.o., Poland
 Type: OB



3.3. Test records

3.3.2. Graphs:

3.2.1. MOBIFRAME type OB-F in FIAT Ducato bodywork.

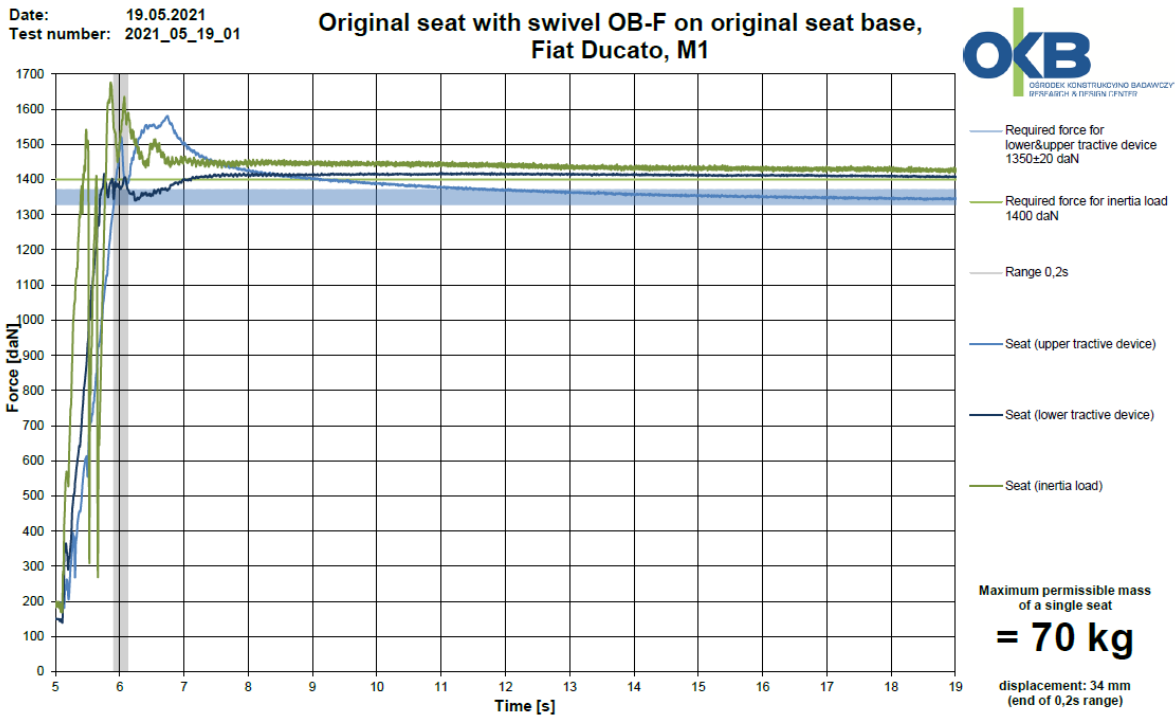

3.2.2. MOBIFRAME type OB-A in VW T5/T6 bodywork.

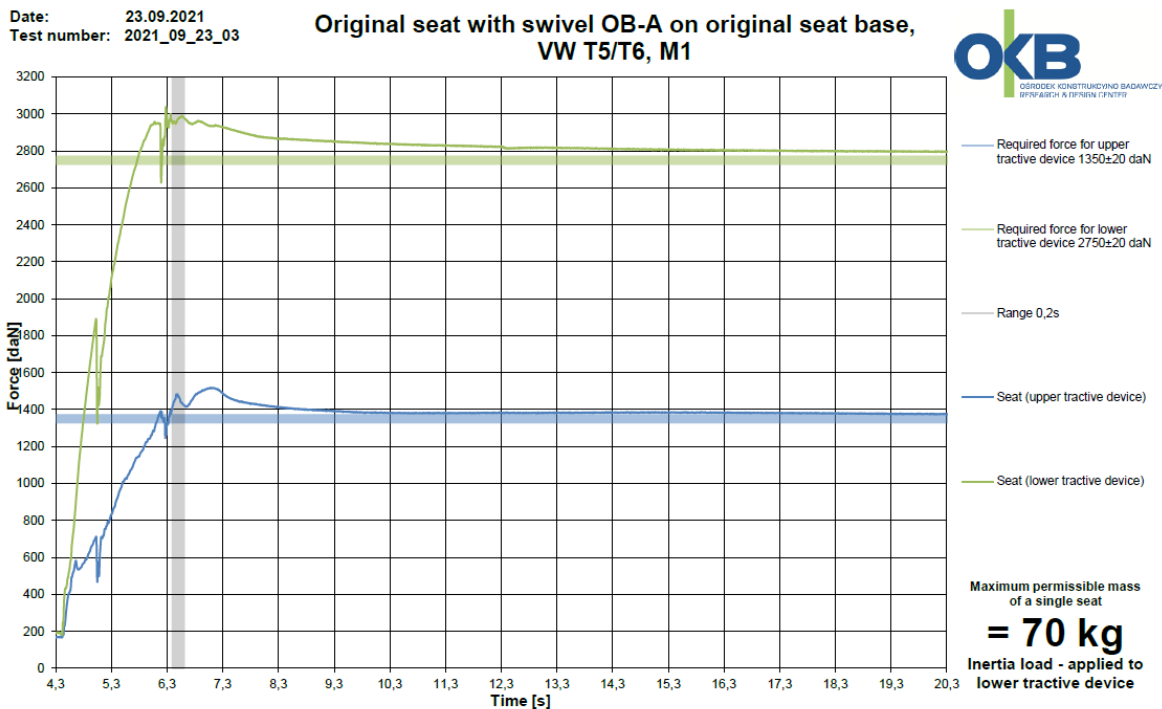

Test report No.: 22-00037-CP-PR-01
 Manufacturer: OKB Sp. z o.o., Poland
 Type: OB



3.2.3. MOBIFRAME type OB-S and OB-V in Mercedes Sprinter 906 and 907 bodywork.

Date: 18.08.2022
 Test number: 2022_08_18_03

Original seat with swivel OB-S on original seat base,
 Mercedes Sprinter 906, M1

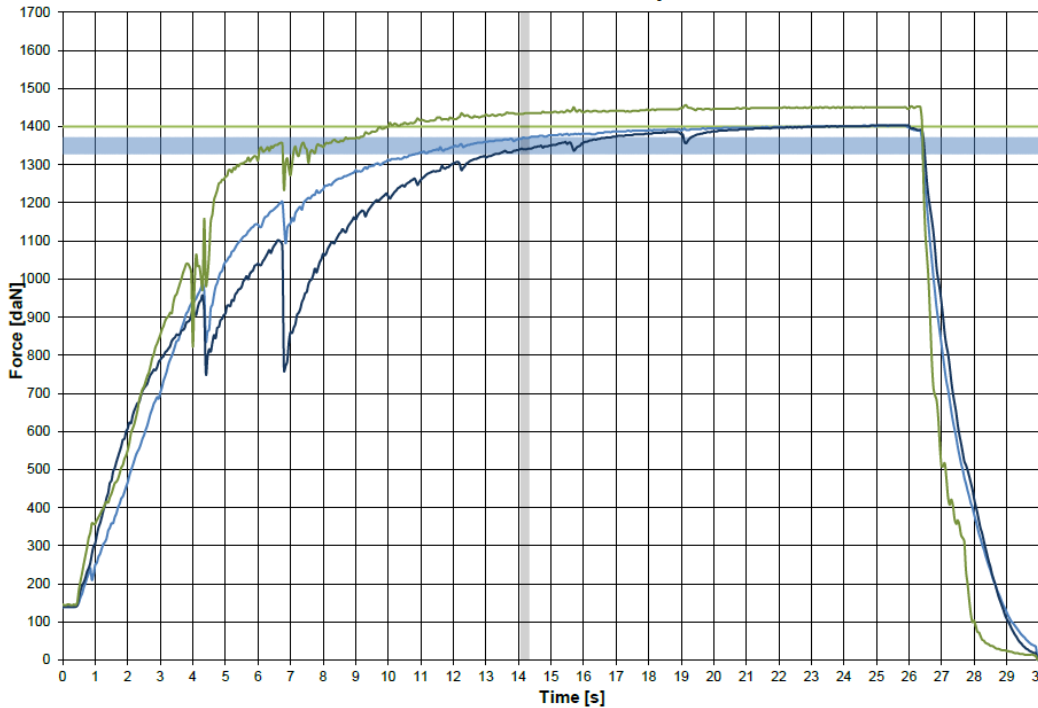

- Required force for lower&upper tractive device 1350±20 daN
- Required force for inertia load 1400 daN
- Range 0,2s
- Seat (upper tractive device)
- Seat (lower tractive device)
- Seat (inertia load)

Maximum permissible mass of a single seat
= 70 kg
 displacement: 27 mm (end of 0,2s range)

Date: 18.08.2022
 Test number: 2022_08_18_03

Original seat with swivel OB-V on original seat base,
 Mercedes Sprinter 907, M1

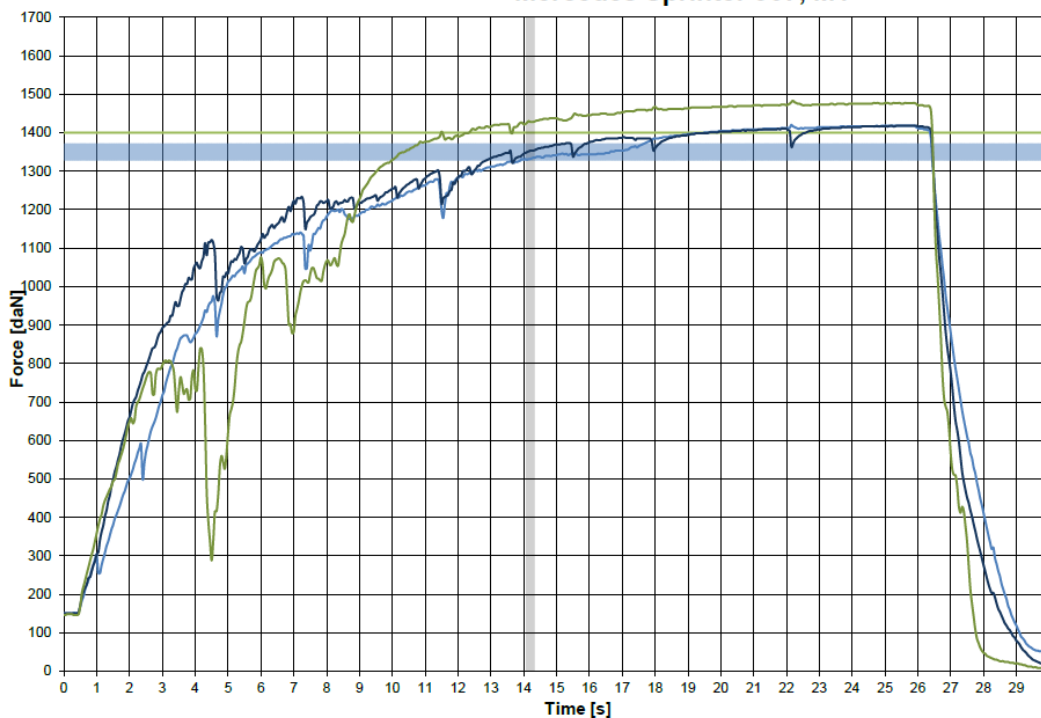

- Required force for lower&upper tractive device 1350±20 daN
- Required force for inertia load 1400 daN
- Range 0,2s
- Seat (upper tractive device)
- Seat (lower tractive device)
- Seat (inertia load)

Maximum permissible mass of a single seat
= 70 kg
 displacement: 39 mm (end of 0,2s range)

Test report No.: 22-00037-CP-PR-01
 Manufacturer: OKB Sp. z o.o., Poland
 Type: OB



3.2.4. MOBIFRAME type OB-T driver's and passenger's seats Ford Transit bodywork.

Date: 19.08.2022
 Test number: 2022_08_19_03

Original driver's seat with swivel OB-T on original seat base, Ford Transit/Transit Custom, M1

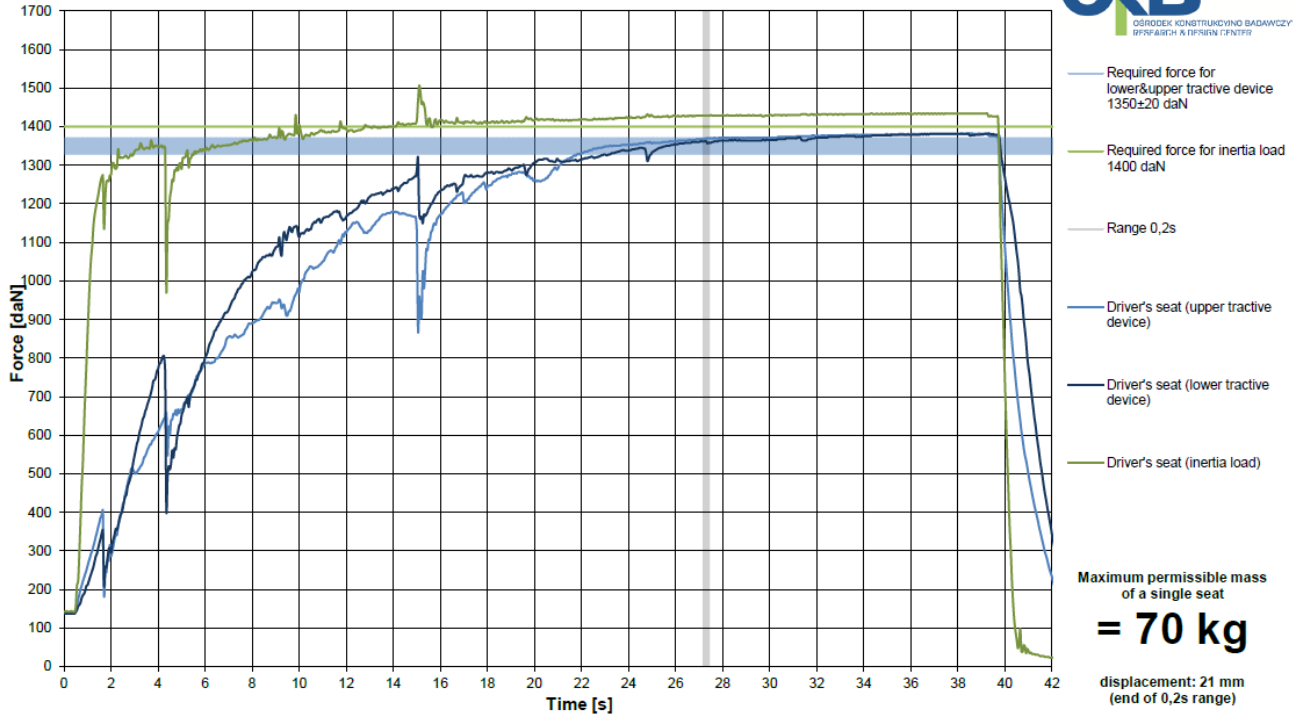

Date: 19.08.2022
 Test number: 2022_08_19_03

Original passenger seat with swivel OB-T on original seat base, Ford Transit/Transit Custom, M1

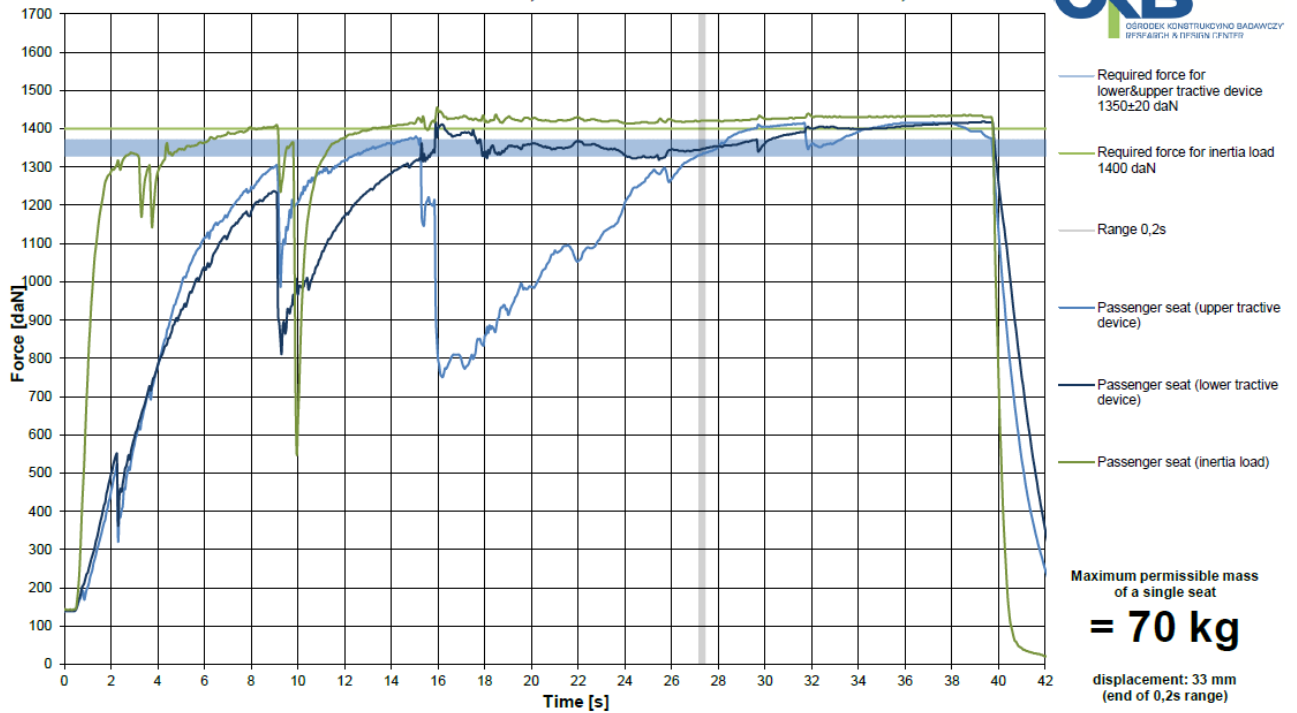

Test report No.: 22-00037-CP-PR-01
 Manufacturer: OKB Sp. z o.o., Poland
 Type: OB



3.2.5. MOBIFRAME type OB-O driver's and passenger's seats Renault Trafic bodywork.

Date: 22.08.2022
 Test number: 2022_08_22_03

Original driver's seat with swivel OB-O on original seat base, Renault Trafic, M1

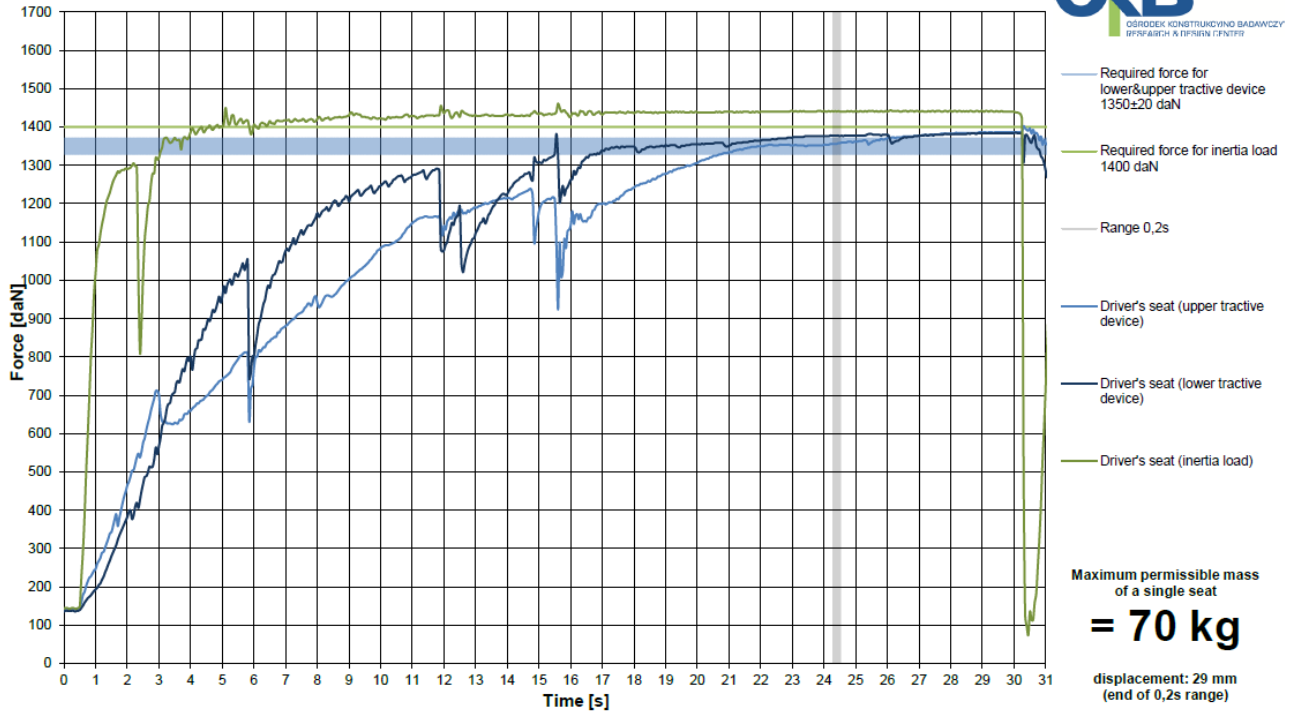

Date: 22.08.2022
 Test number: 2022_08_22_03

Original passenger seat with swivel OB-O on original seat base, Renault Trafic, M1

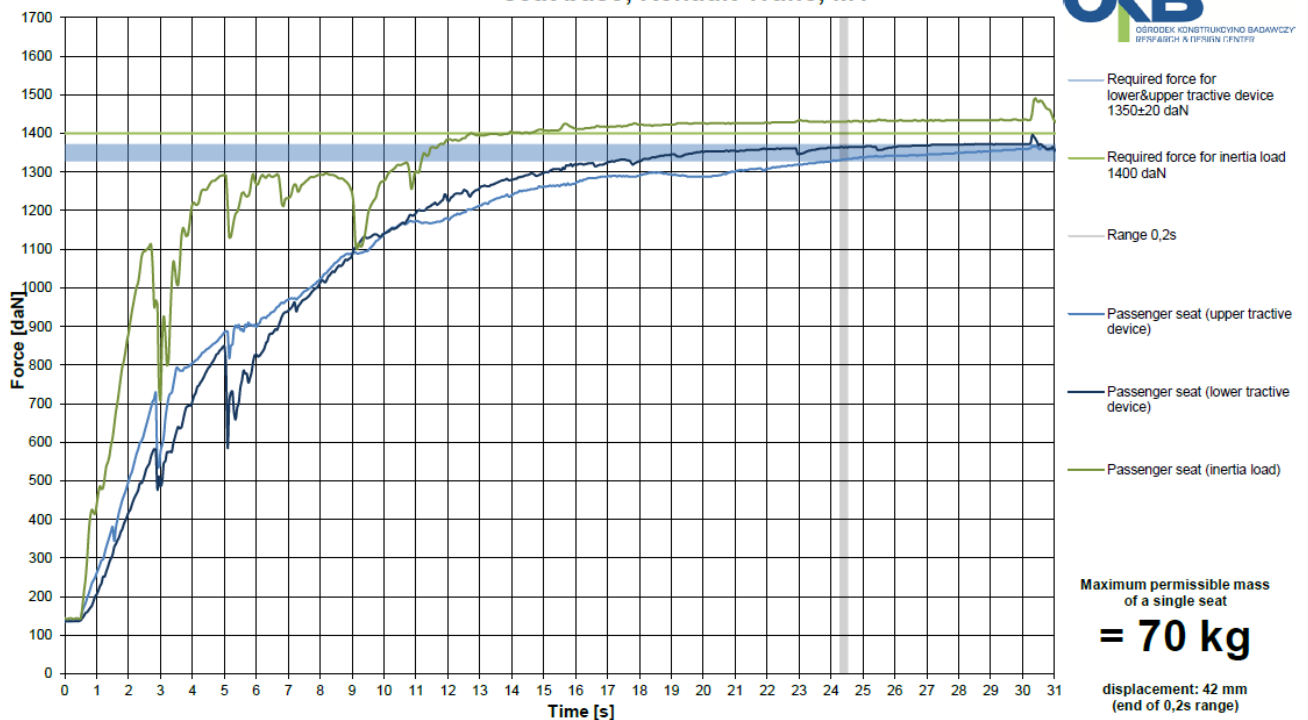

Test report No.: 22-00037-CP-PR-01
 Manufacturer: OKB Sp. z o.o., Poland
 Type: OB



3.2.6. MOBIFRAME type OB-C driver's and passenger's seats Volkswagen Crafter/MAN TGE bodywork.

Date: 23.08.2022
 Test number: 2022_08_23_03

Original driver's seat with swivel OB-C on original seat base, Volkswagen Crafter/MAN TGE, M1

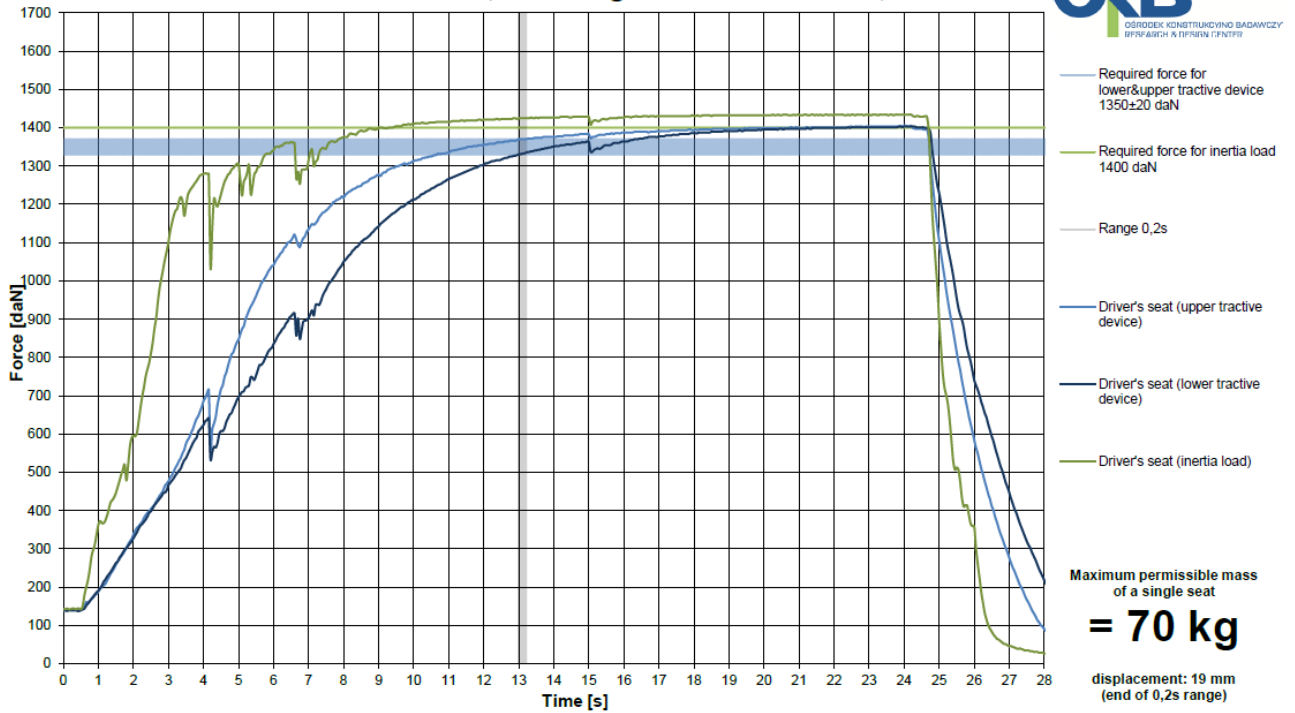

Date: 23.08.2022
 Test number: 2022_08_23_03

Original passenger seat with swivel OB-C on original seat base, Volkswagen Crafter/MAN TGE, M1

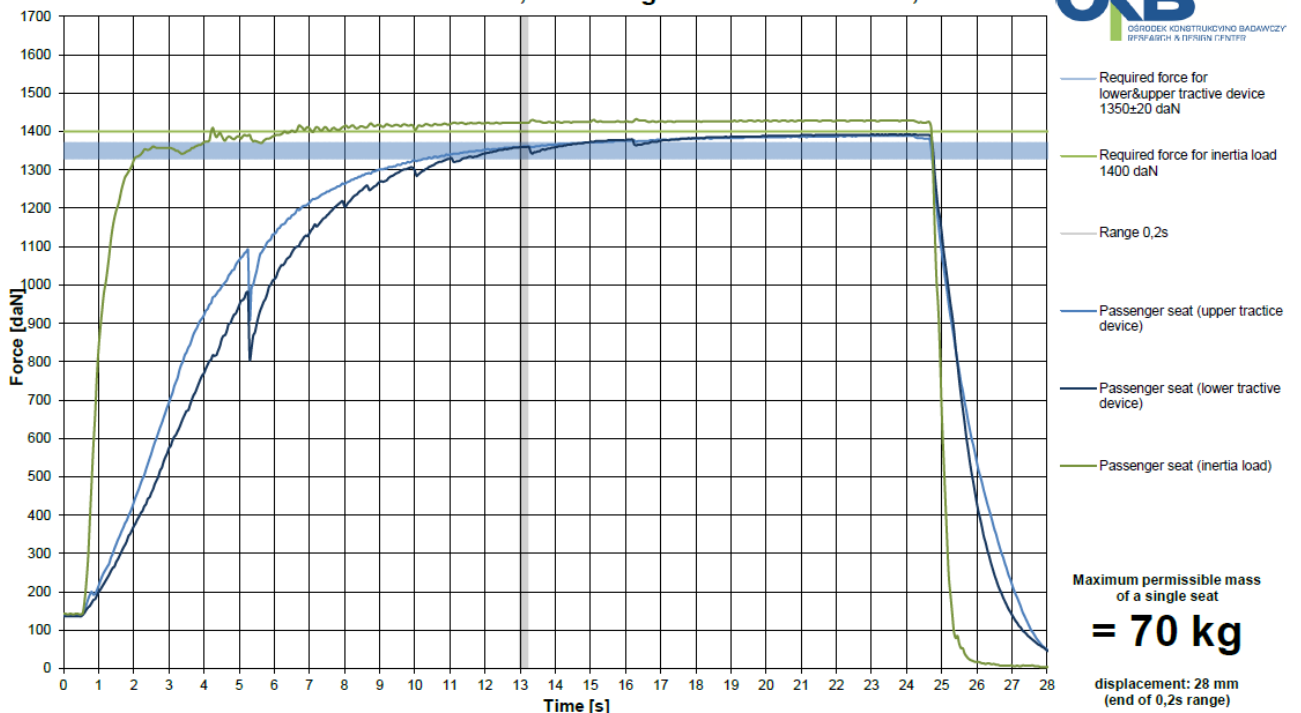

Test report No.: 22-00037-CP-PR-01
 Manufacturer: OKB Sp. z o.o., Poland
 Type: OB



3.2.7. MOBIFRAME type OB-F driver's and passenger's seats Fiat Ducato.

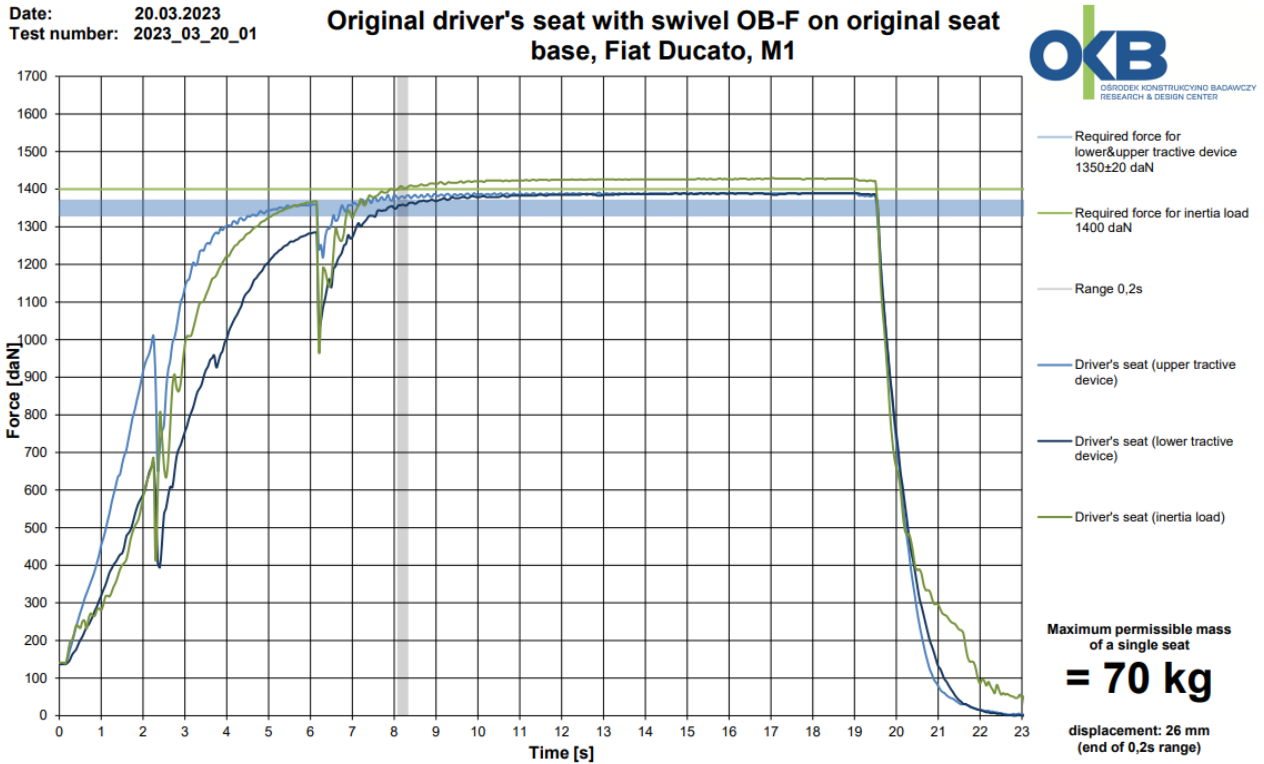

3.2.8. MOBIFRAME type OB-T driver's and passenger's seats Ford Transit/ Transit Custom.

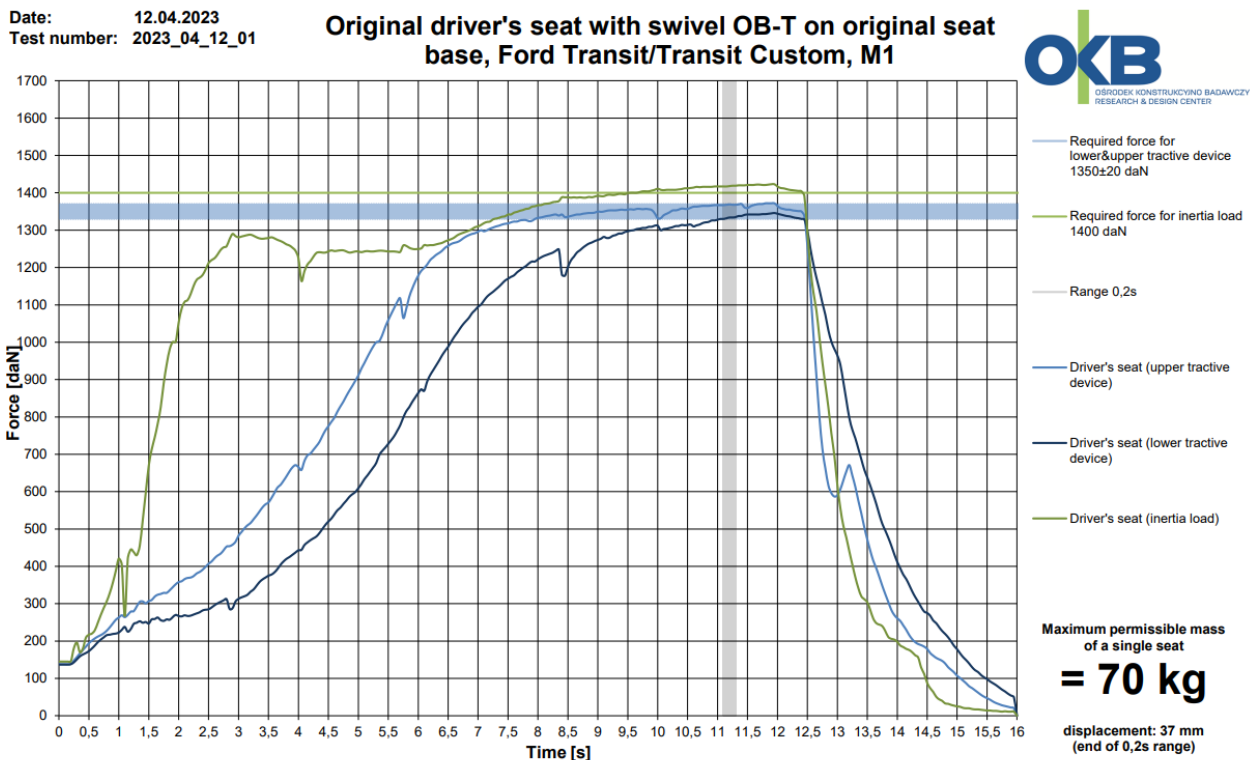

Test report No.: 22-00037-CP-PR-01
Manufacturer: OKB Sp. z o.o., Poland
Type: OB



4. Place and date of testing

As before and 19.05.2021 to 23.08.2022, 26.06.2023

Laboratories with accreditation:

OKB Laboratory, Bukowiec, Poland.

Test report No.: 22-00036-CP-PR-01
Manufacturer: OKB SP. Z O.O., Poland
Type: OB



Test report
No.: 22-00036-CP-PRG-01

Test of a type of a vehicle
with regard to ECE Regulation No. **17.00**
taking into consideration amendment No. **17.09, Supplement 1**
Approval subject: **Strength of seats and their anchorages and head restraints**

Approval status	
Granting of a type approval	N/A
Extension/correction to type approval no.	N/A

Test report only.

Test report No.: 22-00036-CP-PR-01
Manufacturer: OKB SP. Z O.O., Poland
Type: OB



0. Reasons of extension:

- 1. Addition of new vehicles types**
- 2. Addition of new drawings**
- 3. Editorial changes**

I. General

Make: MOBIFRAME
Type: OB
Category of vehicle: M1, M2, N1, N2
Type of bodywork using the codes set out in Part C of Annex II of Directive 2007/46/EC or in Part C of Annex I to Regulation (EU) 2018/858: AC, AF, BB, BA, BX, CA, SA, SH
Name and address of manufacturer: OKB Sp. z o.o.
Szkolna 9, Bukowiec
95-006 Brójce
Poland
Reference number of information folder: MOBIFRAME/02/2022-01
Date of issue of information folder: **26.06.2023**

Test report No.: 22-00036-CP-PR-01
Manufacturer: OKB SP. Z O.O., Poland
Type: OB



II. Test results

Refer to the Annex

III. Enclosures

Information Folder

IV. Statement of conformity

The mentioned information folder and the type described therein are in accordance with the test basis mentioned above. The worst-case was selected in accordance with document "Requirements for Test Reports (AS-PB-T-02)".

The test report may be reproduced and published in full and by the client only. It can be reproduced partially with the written permission of the test laboratory only.

TÜV SÜD Auto Service GmbH is designated as Technical Service by:

Genehmigungsbehörde/ Approval authority	Land/ Country	Registriernummer/ Registration number
Kraftfahrt-Bundesamt (KBA)	Deutschland/ Germany	KBA-P 00100-10
Vehicle Certification Agency (VCA)	Vereinigtes Königreich/ United Kingdom	VCA-TS-006
Approval Authority of the Netherlands (RDW)	Niederlande/ The Netherlands	RDWT-082-xx
National Standards Authority of Ireland (NSAI)	Irland/ Ireland	Technical Service Number: 49
Vehicle Safety Certification Center (VSCC)	Taiwan/ Taiwan	DE04-06-2
Société Nationale de Certification et d'Homologation s.à r.l. (SNCH)	Luxemburg/ Luxembourg	13/B(g)
Swedish Transport Agency (STA)	Schweden/ Sweden	TT 0024

Munich, 30.06.2023



Ing. Vít Bursík
Authorized signatory

Annex

1. Technical data of the test sample

UN Regulation No. 17.09

- 1.1. Test object: Bodyworks of vehicles for which given swivel variant is intended (see section 3 of test report) and MOBIFRAME OB-? Swivels mounted with original base vehicle seats and original seatbelts.
For details see manufacturer's information folder.
- 1.1.1. Location and arrangement:
Seats
Number of seating positions: 1 or 2 (driver and/or passenger)
Location and arrangement: 1st row of seats (in driver's cab)
- 1.1.2. Variant/Version: OB-?
"?" – dedicated for the vehicles:
T – Ford Transit, Ford Transit Custom
S – Mercedes-Benz Sprinter 906,
Volkswagen Crafter 2E???,
Freightliner/Dodge Sprinter
V – Mercedes-Benz Sprinter 907, Sprinter 910, Freightliner/Dodge Sprinter
C – Volkswagen Crafter, MAN TGE
A – Volkswagen T5, Volkswagen T6
F – Fiat Ducato, Peugeot Boxer, Citroen Jumper, Opel/Vauxhall Movano, RAM ProMaster
O – Renault Trafic, Opel/Vauxhall Vivaro, Nissan NV300, Fiat Talento
M – Maxus eDeliver 9, Deliver 9
J – Citroen Jumpy, Peugeot Expert, Fiat Scudo, Toyota ProAce, Opel/Vauxhall Vivaro
- Swivels can also be mounted in electric version of the vehicles.**

Test report No.: 22-00036-CP-PR-01
 Manufacturer: OKB SP. Z O.O., Poland
 Type: OB



1.1.3. Name and address of manufacturer: OKB Sp. z o.o.
 Szkolna 9, Bukowiec
 95-006 Brójce
 Poland

1.1.4. Mass of original driver's/passenger seat and base with additional swivel MOBIFRAME
 OB – 70 kg (allowable mass in the heaviest configuration)

Vehicle(-s)	Maximum mass of original driver's/passenger seat with base	Maximum mass of additional swivel (mounted between original driver's/passenger seat and seat base)
Ford Transit Ford Transit Custom	39 kg	15 kg
MB Sprinter (906) Volkswagen Crafter (2E???) MB Sprinter (907) MB Sprinter (910) Freightliner/Dodge Sprinter	40 kg	
Volkswagen Crafter, MAN TGE	49,8 kg	
Volkswagen T5 Volkswagen T6	40 kg	
Fiat Ducato, Citroën Jumper Peugeot Boxer, Opel/Vauxhall Movano, Ram ProMaster	40,7 kg	
Renault Trafic, Opel/Vauxhall Vivaro Nissan NV300, Fiat Talento	38,4 kg	
Maxus eDeliver 9 Maxus Deliver 9	42,5 kg	
Citroen Jumpy Peugeot Expert Fiat Scudo Toyota ProAce Opel/Vauxhall Vivaro	40,7 kg	

For details see manufacturer's information folder.

Note: Testing laboratory does not bear any responsibility for possibly incorrect values of masses, and dimensions provided by the manufacturer and for test results found out based on these values.

Test report No.: 22-00036-CP-PR-01
 Manufacturer: OKB SP. Z O.O., Poland
 Type: OB



1.1.5. Table of vehicles types for which are test results valid:

Manufacturer	Commercial description / Type	Wheelbase
Daimler / Mercedes-Benz	Sprinter (906, 907)	3250, 3665, 4325
	Sprinter, e-Sprinter (910)	3259, 3924
VW	Crafter (2E_, 3E_)	3250, 3665, 4325
	Crafter e-Crafter (SYN_, SYM_ e.g. SYN1E, SYM1E , SYN2E, SYM2E , SYN2Z, SYM2Z)	3640, 4490
	T5 (7H_, 7E_, 7J_)	3000, 3400
	T6, T6.1, e-Transporter (7H_, 7E_, 7J_)	3000, 3400
Citroen	Jumper, e-Jumper (Y, CY)	3000, 3450, 4035
	Jumpy, e-Jumpy (G9/X, V) (SpaceTourer , E-SpaceTourer (V))	2925, 3275
Peugeot	Boxer (Y)	3000, 3450, 4035
	Expert , e-Expert (G9/X, V) (Traveller , e-Traveller (V))	2925, 3275
Fiat	Ducato, e-Ducato (250)	3000, 3450, 4035
	Talento (FJL, FFL)	3098, 3498
	Scudo (2022-...)	2925, 3275
Opel/Vauxhall	Movano, Movano-e (Y)	3000, 3450, 4035
	Vivaro (F7)	3098, 3498
	Vivaro , Vivaro-e , Vivaro e-Kombi , Vivaro Life (V) (Zafira Life)	2925, 3275
Renault	Trafic (FL, EL , L)	3098, 3498
	Trafic 2014 (JL, L)	3098, 3498
Ford	Transit (FC_)	3300, 3750, 3954
	Transit Custom (FA_, FC_)	2933, 3300
Nissan	NV300, Primastar	3098, 3498
MAN	TGE (SYN_, SYM_ e.g. SYN1E, SYM1E , SYN2E, SYM2E , SYN2Z, SYM2Z)	3640, 4490
Freightliner/Dodge	Sprinter	3250, 3665, 4325
RAM	ProMaster	3000, 3450, 4035
MAXUS	eDeliver 9 , Deliver 9	3000, 3366, 3760
Toyota	Pro Ace , Pro Ace Verso , Pro Ace Electric (X, V)	2925, 3275

1.1.6. Table: Seats and seatbelts anchorages

Driver's and single passenger seat is equipped with additional swivel, which allows to lock the seat in forward-facing direction and rotate about 180 degrees. Swivel is mounted between original driver's/passenger seat and seat base. Details of seat and base construction in type approvals according to UN Reg. No. 14 and UN Reg. No.17 presented in table below

Vehicle(-s)	Number of type approval according to (1 st stage of production)		Max mass of original driver's/passenger seat with base
	ECE R14*	ECE R17*	
Ford Transit Ford Transit Custom	E1 14R07 0732 E1 14R07 0708	E1 17R08 0889 E1 17R08 0864	39 kg
MB Sprinter (906) Volkswagen Crafter (2E???) MB Sprinter (907) MB Sprinter (910) (Freightliner/Dodge Sprinter)	E1 14R-07 0516 E1 14R-07 0524 E1 14R07 0832 E1 14R07 0832	E1 17RA-08 0530 E1 17RA-08 0546 E1 17R08 0982 E1 17R08 0982	40 kg
Volkswagen Crafter MAN TGE	E4 14R-07 0735 E4 14R 070740	E4 17RA-08 0653 E4 17RA 080659	49,8 kg
Volkswagen T5 Volkswagen T6	E4 14R 070097	E4 17RA 080112	40 kg
Fiat Ducato Citroën Jumper Peugeot Boxer Opel/Vauxhall Movano (Ram ProMaster)	E3 14R-07 3133 E3 14R07 2047 E3 14R07 2046 E3 14R07 2046	E3 17RA-08 2953 E3 17RA08 2053 E3 17RA08 2052 E3 17RA09 2052	40,7 kg
Renault Trafic Opel/Vauxhall Vivaro Nissan NV300 Fiat Talento	E2 14R07 1010 E2 14R07 1012 E2 14R07 1011 E2 14R07 15047	E2 17R08 1011 E2 17R08 1013 E2 17R08 1012 E2 17R08 15045	38,4 kg
Maxus eDeliver 9 Maxus Deliver 9	E4 14R08 0904	E4 17R08 0826	42,5 kg
Citroen Jumpy Peugeot Expert Fiat Scudo Toyota ProAce Opel/Vauxhall Vivaro	E2 14R09 15330 E2 14R09 15329 E2 14R09 15329 E2 14R09 15331 E2 14R09 15329	E2 17R09 15340 E2 17R09 15339 E2 17R09 15339 E2 17R09 15341 E2 17R09 15339	40,7 kg

*- applies also to base vehicle partial approvals with newer series of amendments then presented in the table

Swivel can be locked only in forward-facing direction when the vehicle is in motion and in forward-facing direction when the vehicle is stationary.

Anchorage points of seat base to the vehicle floor are the same both before and after swivel installation.

Test report No.: 22-00036-CP-PR-01
Manufacturer: OKB SP. Z O.O., Poland
Type: OB



2. Test conditions

2.1. UN Regulation No. 17.09

2.1.1. Instrumentation:

- Digital ballance
- Dynamic sled test rig
- Seatback and head restraint performance test device
- Accelerometre
- High speed camera
- 3DH-point measurement device

2.1.2. Ambient conditions:

Normal laboratory conditions, not directly limited in Regulation

2.2. Test track or site:

PIMOT Laboratory, Warsaw, Poland

3. Test results

3.1 Test procedures used (UN Reg. No. 17):

Static and dynamic test of strength of seat anchorages, adjustment and displacement mechanisms according to UN Reg. No. 17.09 par. to 5.2.5, 5.2.6., 5.12., 5.13., 5.15. and 6.2.1., 6.3, 6.4.3., 6.4.3.6. and Annex 9 (corridor) with focus on swivelling platform MOBIFRAME type OB.

The below mentioned test results cover all variants including the maximum mass stated in the enclosed information document (seat, seat-to-vehicle anchorages, seat arrangement).

Test report No.: 22-00036-CP-PR-01
 Manufacturer: OKB SP. Z O.O., Poland
 Type: OB



3.2 Static tests:

Description of seats	Head rearward displacement $X < 102$ mm when loaded to moment 373 Nm around R point (Point 6.4.3)	Loading force for head restraint $F \geq 890$ N (point 6.4.3.6)	Strength of the seat back under the load of 530 Nm per seating position (point 6.2.1)
Ford Transit, Transit Custom	73 mm	Pass*	Pass*
Volkswagen T5 / T6	87 mm	Pass*	Pass*
Mercedes-Benz / Dodge / Freightliner Sprinter 907 a 910	72 mm	Pass*	Pass*
Mercedes-Benz / Dodge / Freightliner Sprinter 906, Volkswagen Crafter (type 2E???)	60 mm	Pass*	Pass*
Volkswagen Crafter (type SY???), MAN TGE	63 mm	Pass*	Pass*
Renault Trafic, Opel/Vauxhall Vivaro, Nissan NV300, Fiat Talento	98 mm	Pass*	Pass*
Fiat Ducato, Peugeot Boxer, Citroen Jumper, Opel/Vauxhall Movano, RAM Promaster	52 mm	Pass*	Pass*

* There was no failure in any tested swivel. All swivels were working properly after presented above tests.

3.3 Dynamic tests:

3.3.1 MOBIFRAME type OB for Volkswagen T5 / T6 – frontal impact

Test speed and achieved deceleration

	Requirement	Measured
Impact speed v_0	$50^{+0} -2$ km/h	49,8
Acceleration	corridor	OK – see 3.3

3.3.1.1	Results Paragraph of the regulation ECE 17.09 marked in <i>italics</i>
5.2.5	There was no failure of the swivel unit, seat frame or seat anchorage, adjustment and displacement systems or their locking devices during the test
5.2.6	There was no release of the locking systems during the tests

3.3.2 MOBIFRAME type OB for Fiat Ducato, Peugeot Boxer, Citroen Jumper, Opel Movano, RAM Promaster – rear impact

Test speed and achieved deceleration

	Requirement	Measured
Impact speed v_0	50 ⁺⁰ -2 km/h	49,9
Acceleration	corridor	OK – see 3.3

3.3.2.1 Results

Paragraph of the regulation ECE 17.09 marked in *italics*

5.2.5	There was no failure of the swivel unit, seat frame or seat anchorage, adjustment and displacement systems or their locking devices during the test
5.2.6	There was no release of the locking systems during the tests

3.3.3 MOBIFRAME type OB for

1. Ford Transit and Transit Custom
2. Fiat Ducato, Peugeot Boxer, Citroen Jumper, Opel/Vauxhall Movano, RAM Promaster
3. Renault Trafic, Opel/Vauxhall Vivaro, Nissan NV300, Fiat Talento
4. Mercedes Benz / Dodge / Freightliner: Sprinter 907 and 910
5. Volkswagen Crafter (type SY???) , MAN TGE
6. Mercedes Benz / Dodge / Freightliner Sprinter 906 and Volkswagen Crafter (type 2E???)

frontal impact

Test speed and achieved deceleration

	Requirement	Measured
Impact speed v_0	50 ⁺⁰ -2 km/h	48,4
Acceleration	corridor	OK – see 3.3

3.3.3.1 Results

Paragraph of the regulation ECE 17.09 marked in *italics*

5.2.5	There was no failure of the swivel unit, seat frame or seat anchorage, adjustment and displacement systems or their locking devices during the test
5.2.6	There was no release of the locking systems during the tests

Test report No.: 22-00036-CP-PR-01
 Manufacturer: OKB SP. Z O.O., Poland
 Type: OB



3.3 Dynamic tests:

3.3.4 MOBIFRAME type OB for

1. Ford Transit or Transit Custom
3. Renault Trafic, Opel/Vauxhall Vivaro, Nissan NV300, Fiat Talento
4. Mercedes Benz / Dodge / Freightliner: Sprinter 907 and 910
5. Volkswagen Crafter (type SY???), MAN TGE
6. Mercedes Benz / Dodge / Freightliner Sprinter 906 and Volkswagen Crafter (type 2E???)
7. Volkswagen T5 / T6

rear impact

Test speed and achieved deceleration

	Requirement	Measured
Impact speed v_0	50^{+0}_{-2} km/h	48,9
Acceleration	corridor	OK – see 3.3

3.3.4.1	Results Paragraph of the regulation UN Reg. No. 17.09 marked in <i>italics</i>
5.2.5	There was no failure of the swivel unit, seat frame or seat anchorage, adjustment and displacement systems or their locking devices during the test
5.2.6	There was no release of the locking systems during the tests

Test report No.: 22-00036-CP-PR-01
 Manufacturer: OKB SP. Z O.O., Poland
 Type: OB



3.3.5. Dynamic tests of the seat equipped with swivel adjustment system, in accordance with the test method described in UN Reg. No. 17.09

3.3.5.-1. MOBIFRAME type OB for (OB-F) - frontal impact

1. Fiat Ducato
2. Citroën Jumper
3. Peugeot Boxer
4. Opel/Vauxhall Movano (Ram ProMaster)

Test speed and achieved deceleration

	Requirement	Measured
Impact speed v_0	$50^{+0} -2$ km/h	48,4
Acceleration	corridor	OK – see 3.3

3.3.3.1	Results Paragraph of the regulation ECE 17.09 marked in <i>italics</i>
5.2.5	There was no failure of the swivel unit, seat frame or seat anchorage, adjustment and displacement systems or their locking devices during the test
5.2.6	There was no release of the locking systems during the tests

3.3.5.-2. MOBIFRAME type OB for (OB-F) - rear impact

1. Fiat Ducato
5. Citroën Jumper
6. Peugeot Boxer
7. Opel/Vauxhall Movano (Ram ProMaster)

Test speed and achieved deceleration

	Requirement	Measured
Impact speed v_0	$50^{+0} -2$ km/h	48,9
Acceleration	corridor	OK – see 3.3

3.3.4.1	Results Paragraph of the regulation UN Reg. No. 17.09 marked in <i>italics</i>
5.2.5	There was no failure of the swivel unit, seat frame or seat anchorage, adjustment and displacement systems or their locking devices during the test
5.2.6	There was no release of the locking systems during the tests

Test report No.: 22-00036-CP-PR-01
 Manufacturer: OKB SP. Z O.O., Poland
 Type: OB



3.3.6. UN Reg. No. 17.09 - Vehicle(-s) Maxus Deliver

Swivel	Tests on:	Fulfilling of requirements
OB-M	Maxus Deliver 9 Maxus eDeliver 9	See note. Technical Research no. 23-06-01

3.3.7. UN Reg. No. 17.09 - Vehicle(-s) Citroen Jumpy, Peugeot Expert, Fiat Scudo, Toyota ProAce, Opel/Vauxhall Vivaro.

Swivel	Tests on:	Fulfilling of requirements
OB-J	Citroen Jumpy, Peugeot Expert, Fiat Scudo, Toyota ProAce, Opel/Vauxhall Vivaro.	See note. Technical Research no. 23-06-01

Technical Research no. 23-06-01

Based on the technical analysis of the laboratory and manufacturer: OKB, laboratory, Bukowiec, Poland:

Mobiframe swivels type OB are basing on the same design and structural concept. They are geometrically adapted to each base vehicle seat's fixation points arrangement.

They were tested in multiple bodyworks, which are representative worst cases in terms of fixation points geometry and mass to all swivels presented in this report.

Test report No.: 22-00036-CP-PR-01
Manufacturer: OKB SP. Z O.O., Poland
Type: OB

3.4 Photos before and after static tests

Ford Transit, Transit Custom

H point and torso angle measurement



Test object after static tests



Swivel after static tests



Volkswagen T5 / T6

H point and torso angle measurement



Test object after static tests



Swivel after static tests

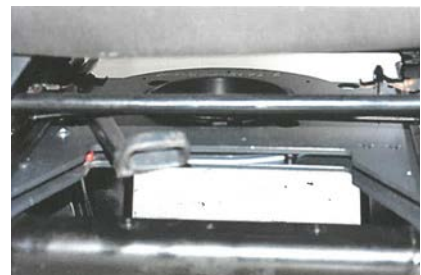

Test report No.: 22-00036-CP-PR-01
Manufacturer: OKB SP. Z O.O., Poland
Type: OB

Mercedes-Benz / Dodge / Freightliner Sprinter 907 a 910

H point and torso angle measurement



Test object after static tests



Swivel after static tests



Mercedes-Benz / Dodge / Freightliner Sprinter 906, Volkswagen Crafter (type 2E???)

H point and torso angle measurement



Test object after static tests



Swivel after static tests



Test report No.: 22-00036-CP-PR-01
Manufacturer: OKB SP. Z O.O., Poland
Type: OB

Volkswagen Crafter (type SY???), MAN TGE

H point and torso angle measurement



Test object after static tests



Swivel after static tests

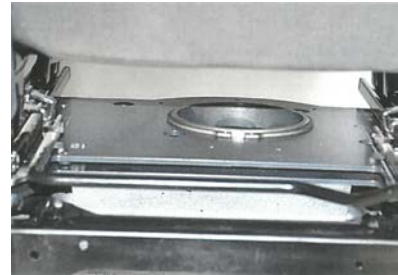

Renault Trafic, Opel/Vauxhall Vivaro, Nissan NV300, Fiat Talento

H point and torso angle measurement



Test object after static tests



Swivel after static tests



Test report No.: 22-00036-CP-PR-01
Manufacturer: OKB SP. Z O.O., Poland
Type: OB

Fiat Ducato, Peugeot Boxer, Citroen Jumper, Opel/Vauxhall Movano, RAM Promaster

H point and torso angle measurement



Test object after static tests



Swivel after static tests

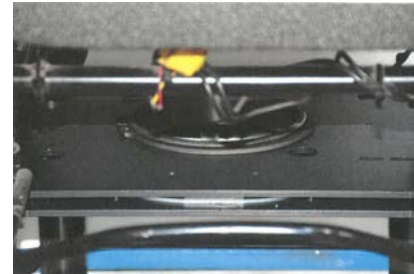

Test report No.: 22-00036-CP-PR-01
Manufacturer: OKB SP. Z O.O., Poland
Type: OB

3.5 Test records and photos from dynamic tests– diagrams

VW T6 – graph of frontal impact

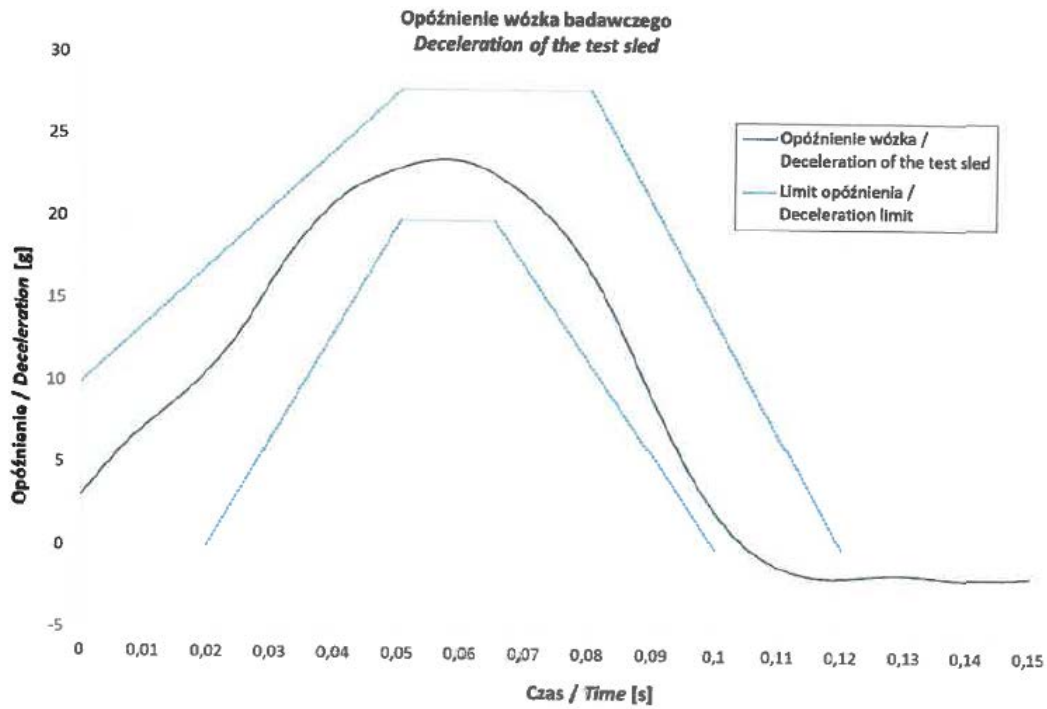

VW T6 – photos before test



VW T6 – photos after test



Test report No.: 22-00036-CP-PR-01
Manufacturer: OKB SP. Z O.O., Poland
Type: OB

FIAT Ducato – rearward impact

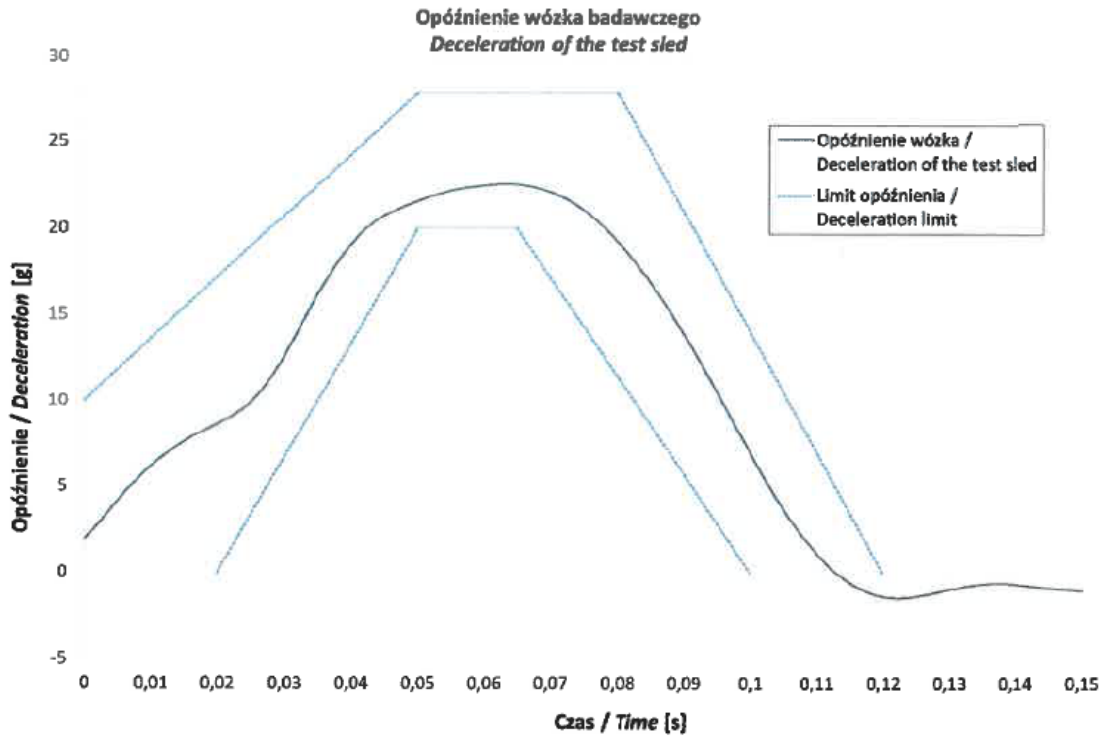

FIAT Ducato – photos before test

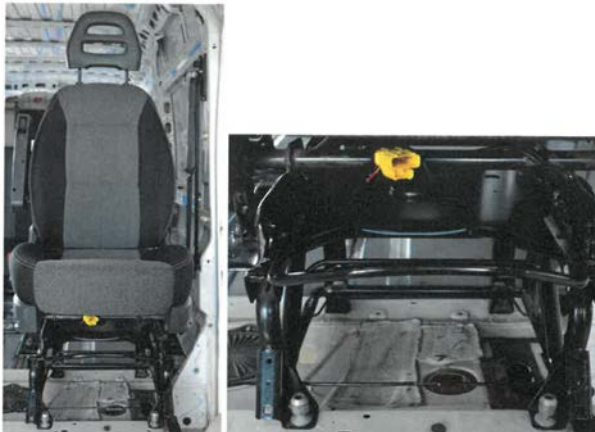

FIAT Ducato – photos after test



Test report No.: 22-00036-CP-PR-01
Manufacturer: OKB SP. Z O.O., Poland
Type: OB

Photo of seats from point 3.3.3 – frontal impact



Photo before test

Photo after test



Test report No.: 22-00036-CP-PR-01
Manufacturer: OKB SP. Z O.O., Poland
Type: OB



Graph of the test with seats from point 3.3.3– frontal impact

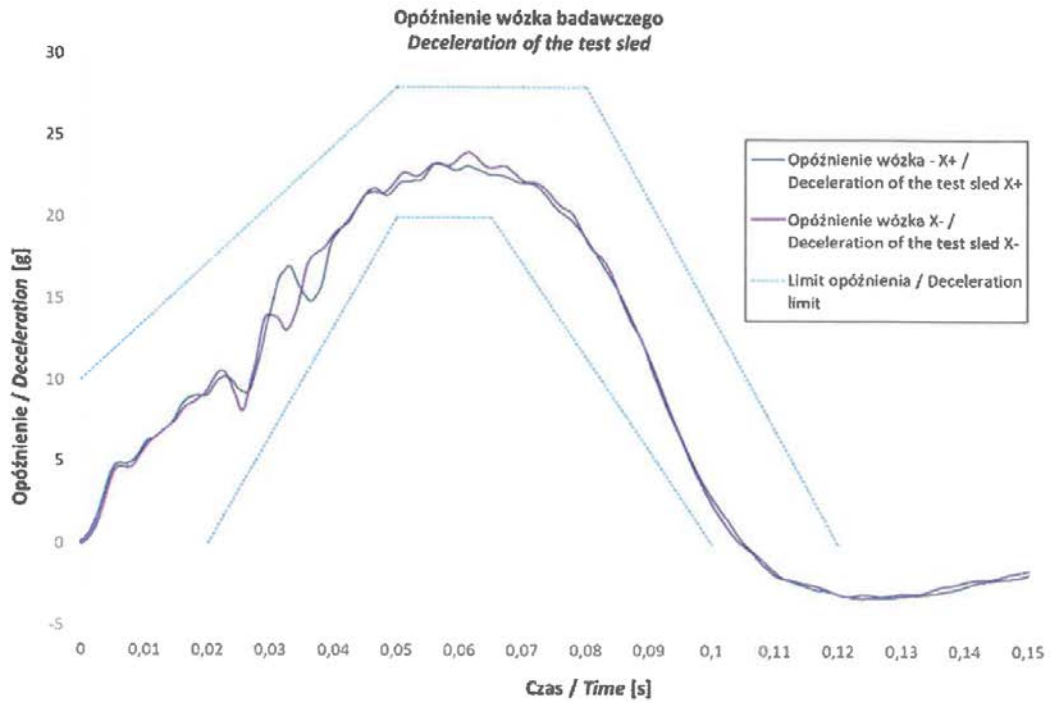

Test report No.: 22-00036-CP-PR-01
Manufacturer: OKB SP. Z O.O., Poland
Type: OB



Auto Service

Photo of seats from point 3.3.4 – rear impact

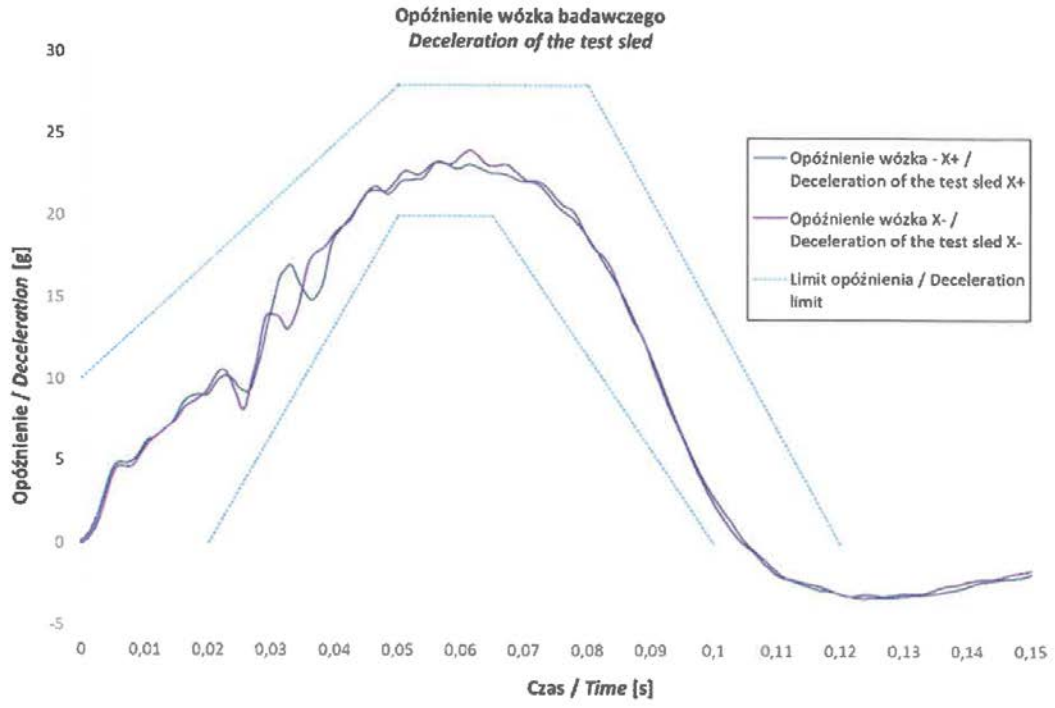

Photo before test

Photo after test



Graph of the test with seats from point 3.3.4 – rear impact



**3.3.5.-1. Dynamic tests of the seat equipped with swivel adjustment system, in accordance with the test method described in UN Reg. No. 17.09
MOBIFRAME type OB for (OB-F) - frontal impact**

Photo of seat from point 3.3.5 – frontal impact



Graph of seat from point 3.3.5. –1. – frontal impact

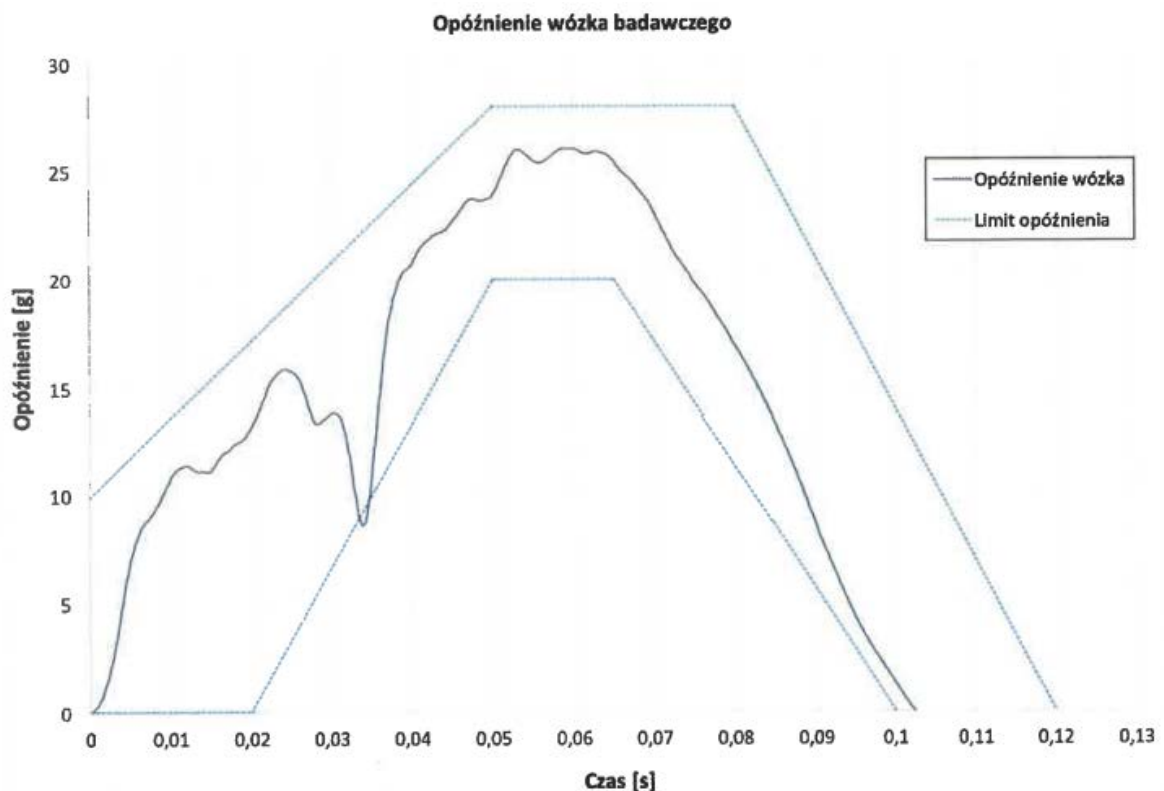

**3.3.5.-2. Dynamic tests of the seat equipped with swivel adjustment system, in accordance with the test method described in UN Reg. No. 17.09
MOBIFRAME type OB for (OB-F) - rear impact**

Photo of seat from point 3.3.5. -2.– rear impact



Graph of seat from point 3.3.5.-2. – rear impact

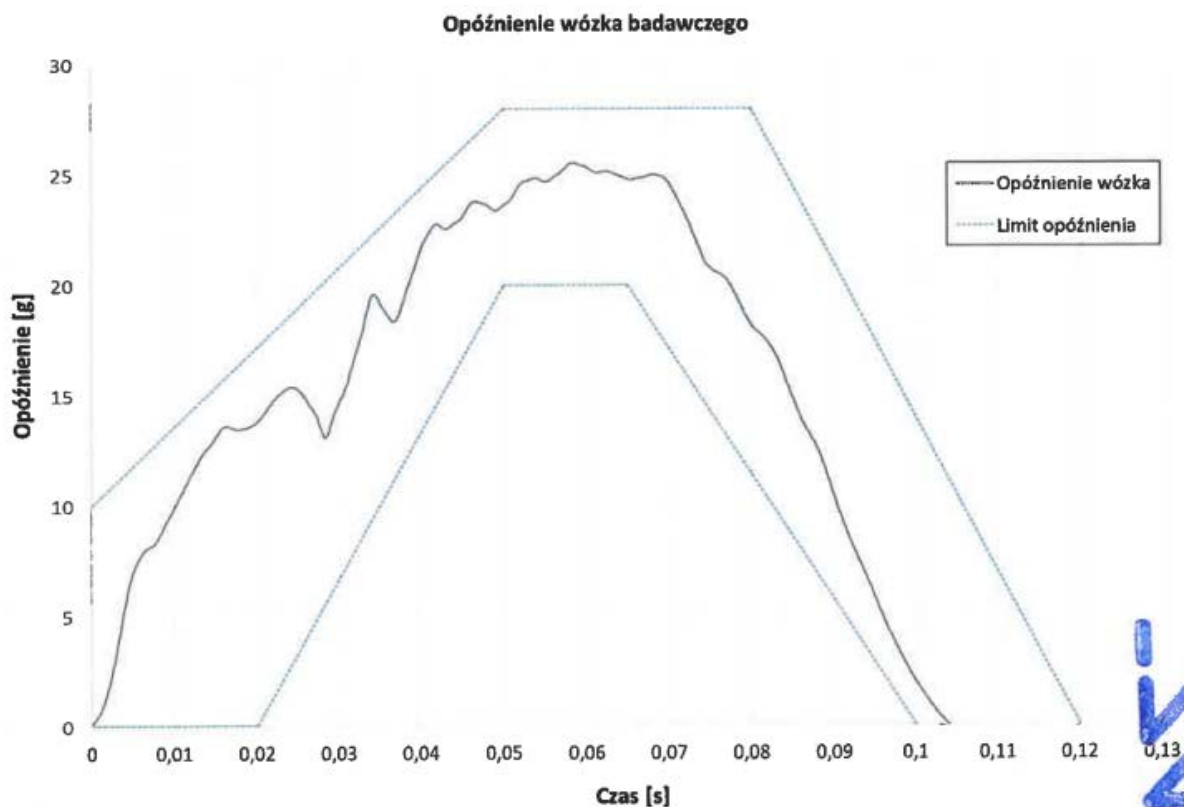

Test report No.: 22-00036-CP-PR-01
Manufacturer: OKB SP. Z O.O., Poland
Type: OB



4. Place and date of testing

PIMOT Laboratory, Warsaw, Poland
From 15.07.2022 to 21.07.2022 and 13.03.2023

INFORMATION FOLDER / DOCUMENT:
MOBIFRAME/02/2022-01

PURSUANT TO UN/ECE REGULATIONS
No. 14-09
“UNIFORM PROVISIONS CONCERNING THE APPROVAL OF VEHICLES WITH
REGARD TO SAFETY-BELT ANCHORAGES“

FOR THE SEATS EQUIPPED WITH SWIVEL *MOBIFRAME*
TYPE *OB*

No. 17-09
“UNIFORM PROVISIONS CONCERNING THE APPROVAL OF VEHICLES WITH
REGARD TO THE SEATS, THEIR ANCHORAGES AND ANY HEAD RESTRAINTS”

FOR THE SEATS EQUIPPED WITH SWIVEL *MOBIFRAME*
TYPE *OB*

Reasons to extension:

- addition of new vehicles types
- addition of new drawings
- editorial changes



.....
Damian Goliński
Vice President

Total number of pages: **29**
Date of issue: **26.06.2023**



		Date: 26.06.2023
	<i>MOBIFRAME/02/2022-01</i>	Page / pages: 1/29

List of documentation and supplements

Confirmation.....	3
0. General.....	4
1. General construction characteristics of the vehicle	5
9. Bodywork.....	5

List of enclosures

Table of vehicles types	Enclosure 1
Seats and seat belt anchorages	Enclosure 2
Seat anchorages	Enclosure 3



	Date: 26.06.2023
MOBIFRAME/02/2022-01	Page / pages: 2/29

Confirmation

We hereby declare that the vehicle specimens submitted for this approval test have been manufactured and assembled on conditions of ordinary mass production and that they are compatible with the enclosed documentation.

Date of issue: 26th June 2023



.....
Damian Goliński
Vice President



		Date: 26.06.2023
	MOBIFRAME/02/2022-01	Page / pages: 3/29

0. GENERAL

0.1 Make (trade name of manufacturer): MOBIFRAME

0.2 Type: OB

Variant/Version:

OB-?

”?” – dedicated for the vehicles:

T – Ford Transit, Ford Transit Custom

S – Mercedes-Benz Sprinter 906,
Volkswagen Crafter 2E???,
Freightliner/Dodge Sprinter

V – Mercedes-Benz Sprinter 907, Sprinter
910, Freightliner/Dodge Sprinter

C – Volkswagen Crafter, MAN TGE

A – Volkswagen T5, Volkswagen T6

F – Fiat Ducato, Peugeot Boxer, Citroen
Jumper, Opel/Vauxhall Movano, RAM
ProMaster

O – Renault Trafic, Opel/Vauxhall Vivaro,
Nissan NV300, Fiat Talento

M – Maxus eDeliver 9, Deliver 9

**J – Citroen Jumpy, Peugeot Expert, Fiat
Scudo, Toyota ProAce, Opel/Vauxhall
Vivaro**

**Swivels can also be mounted in electric
version of the vehicles.**

0.2.1 Dedicated for vehicle(s): See Enclosure 1

0.4 Category of vehicle: M1, N1, M2, N2

0.5 Name and address of manufacturer: OKB SP. Z O.O.
ul. Szkolna 9, Bukowiec
95-006 Brójce
Poland



		Date: 26.06.2023
	MOBIFRAME/02/2022-01	Page / pages: 4/29

1. GENERAL CONSTRUCTION CHARACTERISTICS OF THE VEHICLE
- 1.1 Photographs and/or drawings of a representative vehicle: See base vehicle approvals listed in Enclosure 2
9. BODYWORK
- 9.1 Type of bodywork using the codes set out in Part C of Annex II of Directive 2007/46/EC or in Part C of Annex I to Regulation (EU) 2018/858: AC, AF, BB, BA, BX, CA, SA, SH
- 9.10 Interior arrangement
- 9.10.3 Seats
- 9.10.3.1 Number of seating positions: 1 or 2 (driver and/or passenger)
- 9.10.3.1.1 Location and arrangement: 1st row of seats (in driver's cab)
- 9.10.3.2 Seat(s) designated for use only when the vehicle is stationary: N/A
- 9.10.3.3 Mass:
Mass of original driver's/passenger seat and base with additional swivel MOBIFRAME OB – 70 kg (allowable mass in the heaviest configuration)



		Date: 26.06.2023
	MOBIFRAME/02/2022-01	Page / pages: 5/29

Vehicle(-s)	Maximum mass of original driver's/passenger seat with base	Maximum mass of additional swivel (mounted between original driver's/passenger seat and seat base)
Ford Transit Ford Transit Custom	39 kg	15 kg
MB Sprinter (906) Volkswagen Crafter (2E???) MB Sprinter (907) MB Sprinter (910) Freightliner/Dodge Sprinter	40 kg	
Volkswagen Crafter, MAN TGE	49,8 kg	
Volkswagen T5 Volkswagen T6	40 kg	
Fiat Ducato, Citroën Jumper Peugeot Boxer, Opel/Vauxhall Movano, Ram ProMaster	40,7 kg	
Renault Trafic, Opel/Vauxhall Vivaro Nissan NV300, Fiat Talento	38,4 kg	
Maxus eDeliver 9 Maxus Deliver 9	42,5 kg	
Citroen Jumpy Peugeot Expert Fiat Scudo Toyota ProAce Opel/Vauxhall Vivaro	40,7 kg	

Details – see Enclosures

- 9.10.3.4 Characteristics: for seats not type-approved as components, description and drawings of
- 9.10.3.4.1 The seats and their anchorages: See base vehicle approvals listed in Enclosure 2 and Enclosure 3
- 9.10.3.4.2 The adjustment system: See base vehicle approvals listed in Enclosure 2
- 9.10.3.4.3 The displacement and locking systems: See listed base vehicle approvals and description in Enclosure 2
- 9.10.3.4.4 The seat-belt anchorages (if incorporated in the seat structure): See base vehicle approvals listed in Enclosure 2
- 9.10.3.4.5 The parts of the vehicle used as anchorages: See base vehicle approvals listed in Enclosure 2
- 9.10.3.5 Coordinates or drawing of the R-point
- 9.10.3.5.1 Driver's seat: See base vehicle approvals listed in Enclosure 2
- 9.10.3.5.2 All other seating positions: See base vehicle approvals listed in Enclosure 2

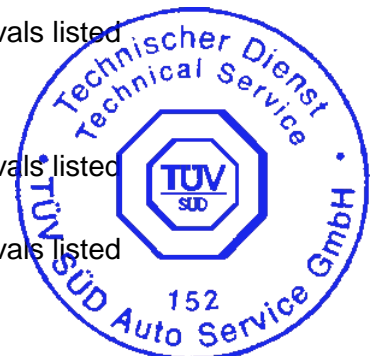

	Date: 26.06.2023
MOBIFRAME/02/2022-01	Page / pages: 6/29

- 9.10.3.6 Design torso angle
- 9.10.3.6.1 Driver's seat: See base vehicle approvals listed in Enclosure 2
- 9.10.3.6.2 All other seating positions: See base vehicle approvals listed in Enclosure 2
- 9.10.3.7 Range of seat adjustment
- 9.10.3.7.1 Driver's seat: See base vehicle approvals listed in Enclosure 2
- 9.10.3.7.2 All other seating positions: See base vehicle approvals listed in Enclosure 2
- 9.10.4. Head restraints
- 9.10.4.1. Type(s) of head restraints: See base vehicle approvals listed in Enclosure 2
- 9.10.4.2. Type-approval number(s), if available: See base vehicle approvals listed in Enclosure 2
- 9.10.4.3. For head restraints not yet approved See base vehicle approvals listed in Enclosure 2
- 9.13 Safety belt anchorages
- 9.13.1 Photographs and/or drawings of the bodywork showing the position and dimensions of the actual and effective anchorages including the R-points: See base vehicle approvals listed in Enclosure 2 and Enclosure 3
- 9.13.2 Drawings of the belt anchorages and parts of the vehicle structure where they are attached (with the material indication): See base vehicle approvals listed in Enclosure 2
- 9.13.3 Designation of the types of safety belt authorised for fitting to the anchorages with which the vehicle is equipped:

	Anchorage location	
	Vehicle structure	Seat structure
First row of seats	See base vehicle approvals listed in Enclosure 2	See base vehicle approvals listed in Enclosure 2

- 9.13.4 Description of a particular type of safety belt where an anchorage is located in the seat backrest or incorporates an energy dissipating device: See base vehicle approvals listed in Enclosure 2

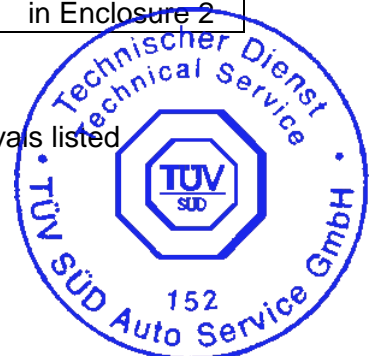

Enclosure 1: TABLE OF VEHICLES TYPES

Manufacturer	Commercial description / Type	Wheelbase
Daimler / Mercedes-Benz	Sprinter (906, 907)	3250, 3665, 4325
	Sprinter, e-Sprinter (910)	3259, 3924
VW	Crafter (2E_, 3E_)	3250, 3665, 4325
	Crafter e-Crafter (SYN_, SYM_ e.g. SYN1E, SYM1E , SYN2E, SYM2E , SYN2Z, SYM2Z)	3640, 4490
	T5 (7H_, 7E_, 7J_)	3000, 3400
	T6, T6.1, e-Transporter (7H_, 7E_, 7J_)	3000, 3400
Citroen	Jumper, e-Jumper (Y, CY)	3000, 3450, 4035
	Jumpy, e-Jumpy (G9/X, V) (SpaceTourer, E-SpaceTourer (V))	2925, 3275
Peugeot	Boxer (Y)	3000, 3450, 4035
	Expert, e-Expert (G9/X, V) (Traveller, e-Traveller (V))	2925, 3275
Fiat	Ducato, e-Ducato (250)	3000, 3450, 4035
	Talento (FJL, FFL)	3098, 3498
	Scudo (2022-...)	2925, 3275
Opel/Vauxhall	Movano, Movano-e (Y)	3000, 3450, 4035
	Vivaro (F7)	3098, 3498
	Vivaro, Vivaro-e, Vivaro e-Kombi, Vivaro Life (V) (Zafira Life)	2925, 3275
Renault	Trafic (FL, EL , L)	3098, 3498
	Trafic 2014 (JL, L)	3098, 3498
Ford	Transit (FC_)	3300, 3750, 3954
	Transit Custom (FA_, FC_)	2933, 3300
Nissan	NV300, Primastar	3098, 3498
MAN	TGE (SYN_, SYM_ e.g. SYN1E, SYM1E , SYN2E, SYM2E , SYN2Z, SYM2Z)	3640, 4490
Freightliner/Dodge	Sprinter	3250, 3665, 4325
RAM	ProMaster	3000, 3450, 4035
MAXUS	eDeliver 9, Deliver 9	3000, 3366, 3760
Toyota	Pro Ace, Pro Ace Verso, Pro Ace Electric (X, V)	2925, 3275



	Date: 26.06.2023
MOBIFRAME/02/2022-01	Page / pages: 8/29

Enclosure 2: SEATS AND SEATBELTS ANCHORAGES

Driver's and single passenger seat is equipped with additional swivel, which allows to lock the seat in forward-facing direction and rotate about 180 degrees. Swivel is mounted between original driver's/passenger seat and seat base. Details of seat and base construction in type approvals according to ECE R14 and ECE R17 presented in table below.

Vehicle(-s)	Number of type approval according to (1 st stage of production)		Max mass of original driver's/passenger seat with base
	ECE R14*	ECE R17*	
Ford Transit Ford Transit Custom	E1 14R07 0732 E1 14R07 0708	E1 17R08 0889 E1 17R08 0864	39 kg
MB Sprinter (906) Volkswagen Crafter (2E???) MB Sprinter (907) MB Sprinter (910) (Freightliner/Dodge Sprinter)	E1 14R-07 0516 E1 14R-07 0524 E1 14R07 0832 E1 14R07 0832	E1 17RA-08 0530 E1 17RA-08 0546 E1 17R08 0982 E1 17R08 0982	40 kg
Volkswagen Crafter MAN TGE	E4 14R-07 0735 E4 14R 070740	E4 17RA-08 0653 E4 17RA 080659	49,8 kg
Volkswagen T5 Volkswagen T6	E4 14R 070097	E4 17RA 080112	40 kg
Fiat Ducato Citroën Jumper Peugeot Boxer Opel/Vauxhall Movano (Ram ProMaster)	E3 14R-07 3133 E3 14R07 2047 E3 14R07 2046 E3 14R07 2046	E3 17RA-08 2953 E3 17RA08 2053 E3 17RA08 2052 E3 17RA09 2052	40,7 kg
Renault Trafic Opel/Vauxhall Vivaro Nissan NV300 Fiat Talento	E2 14R07 1010 E2 14R07 1012 E2 14R07 1011 E2 14R07 15047	E2 17R08 1011 E2 17R08 1013 E2 17R08 1012 E2 17R08 15045	38,4 kg
Maxus eDeliver 9 Maxus Deliver 9	E4 14R08 0904	E4 17R08 0826	42,5 kg
Citroen Jumpy Peugeot Expert Fiat Scudo Toyota ProAce Opel/Vauxhall Vivaro	E2 14R09 15330 E2 14R09 15329 E2 14R09 15329 E2 14R09 15331 E2 14R09 15329	E2 17R09 15340 E2 17R09 15339 E2 17R09 15339 E2 17R09 15341 E2 17R09 15339	40,7 kg

*- applies also to base vehicle partial approvals with newer series of amendments then presented in the table

Swivel can be locked only in forward-facing direction when the vehicle is in motion and in forward-facing direction when the vehicle is stationary.

Anchorage points of seat base to the vehicle floor are the same both before and after swivel installation.



	Date: 26.06.2023
MOBIFRAME/02/2022-01	Page / pages: 9/29

Enclosure 3: SEAT ANCHORAGES

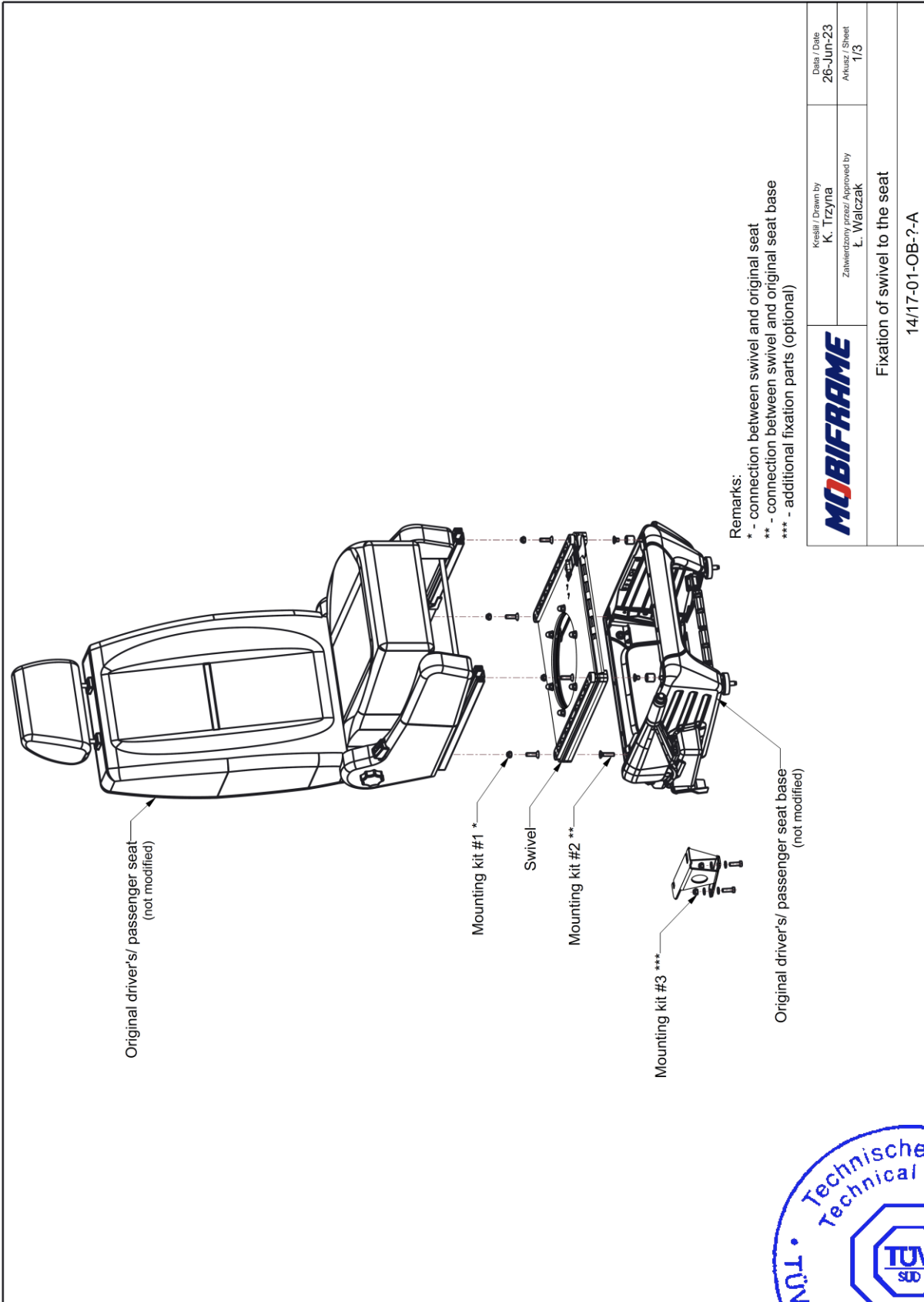

MOBIFRAME	Kreslił / Drawn by K. Trzyna	Data / Date 26-Jun-23
	Zatwierdzony przez / Approved by Ł. Wajczak	Arkusz / Sheet 1/3
Fixation of swivel to the seat		
14/17-01-OB-?-A		



	Date: 26.06.2023
MOBIFRAME/02/2022-01	Page / pages: 10/29

VEHICLE	SIDE	MOUNTING KIT #1	MOUNTING KIT #2	MOUNTING KIT #3
Ford Transit Transit Custom	Driver	4x DIN 7991 bolt M8 - 10.9 4x DIN 985 nut M8	4x DIN 7991 M8 - 10.9	3x DIN 7991 bolt M8 - 10.9 3x DIN 933 bolt M8 - 8.8 6x DIN 985 self-locking nut M8
	Passenger	4x DIN 7991 bolt M8 - 10.9 4x DIN 985 nut M8	4x DIN 7991 M8 - 10.9	-
Mercedes-Benz Sprinter 906 Volkswagen Crafter 2E???	Driver	4x DIN 7991 bolt M10 - 10.9 4x DIN 985 nut M10	4x DIN 7991 bolt M10 - 10.9	2x DIN 7991 bolt M10 - 10.9 2x DIN 933 bolt M10 - 8.8
	Passenger	4x DIN 7991 bolt M10 - 10.9 4x DIN 985 nut M10	4x DIN 7991 bolt M10 - 10.9	-
Mercedes-Benz Sprinter 907 Sprinter 910 Freightliner/Dodge Sprinter	Driver	4x DIN 7991 bolt M10 - 10.9 4x DIN 985 nut M8	4x DIN 7991 bolt M10 - 10.9	2x DIN 7991 bolt M10 - 10.9 2x DIN 933 bolt M10 - 8.8
	Passenger	4x DIN 7991 bolt M10 - 10.9 4x DIN 985 nut M8	4x DIN 7991 bolt M10 - 10.9	-
Volkswagen Crafter (SY???) MAN TGE (SY???)	Driver	4x DIN 7991 bolt M10 - 10.9 4x EB 88953 washer M10	4x DIN 7991 bolt M10 - 10.9	4x ISO 7380-1 bolt M8 - 10.9 8x ISO 7091 washer M8 4x DIN 985 nut M8
	Passenger	4x DIN 7991 bolt M10 - 10.9 4x EB 88953 washer M10	4x DIN 7991 bolt M10 - 10.9	-
Volkswagen T5/T6	Driver	4x DIN 7991 bolt M8 - 10.9 4x DIN 985 nut M8	4x DIN 7991 bolt M8 - 10.9	2x DIN 933 bolt M8 - 10.9 4x ISO 7091 washer M8 2x DIN 985 nut M8
	Passenger	4x DIN 7991 bolt M8 - 10.9 4x DIN 985 nut M8	4x DIN 7991 bolt M8 - 10.9	-
Fiat Ducato Citroën Jumper Opel/Vauxhall Movano Peugeot Bocer RAM ProMaster	Driver	6x DIN 7991 bolt M8 - 10.9 6x DIN 985 nut M8	6x DIN 7991 bolt M8 - 10.9	-
	Passenger	6x DIN 7991 bolt M8 - 10.9 6x DIN 985 nut M8	6x DIN 7991 bolt M8 - 10.9	-
Renault Traffic Opel Vivaro Nissan NV300 Fiat Talento	Driver	4x DIN 7991 bolt M10 - 10.9 4x DIN 985 nut M10	4x DIN 7991 bolt M10 - 10.9	-
	Passenger	4x DIN 7991 bolt M10 - 10.9 4x DIN 985 nut M10	4x DIN 7991 bolt M10 - 10.9	-
Maxus eDeliver 9 Deliver 9	Driver	4x DIN 7991 bolt M10 - 10.9 4x DIN 985 nut M10	4x DIN 7991 bolt M10 - 10.9	-
	Passenger	4x DIN 7991 bolt M10 - 10.9 4x DIN 985 nut M10	4x DIN 7991 bolt M10 - 10.9	-
Citroën Jumpy Peugeot Expert Fiat Scudo Toyota ProAce Opel Vivaro	Driver	4x DIN 7991 bolt M10 - 10.9 4x DIN 985 nut M10	4x DIN 7991 bolt M10 - 10.9	3x DIN 933 bolt M10 - 8.8 5x ISO 7090 washer M10 3x DIN 985 nut M10
	Passenger	4x DIN 7991 bolt M10 - 10.9 4x DIN 985 nut M10	4x DIN 7991 bolt M10 - 10.9	-



Kresli / Drawn by
K. Trzyna
Zatwierdzony przez / Approved by
L. Walczak

Date / Date
26-Jun-23
Arkusz / Sheet
2/3

Fixation of swivel to the seat

14/17-01-OB-?-A

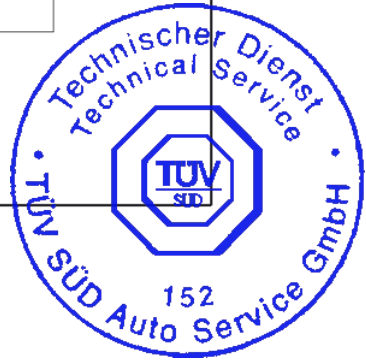

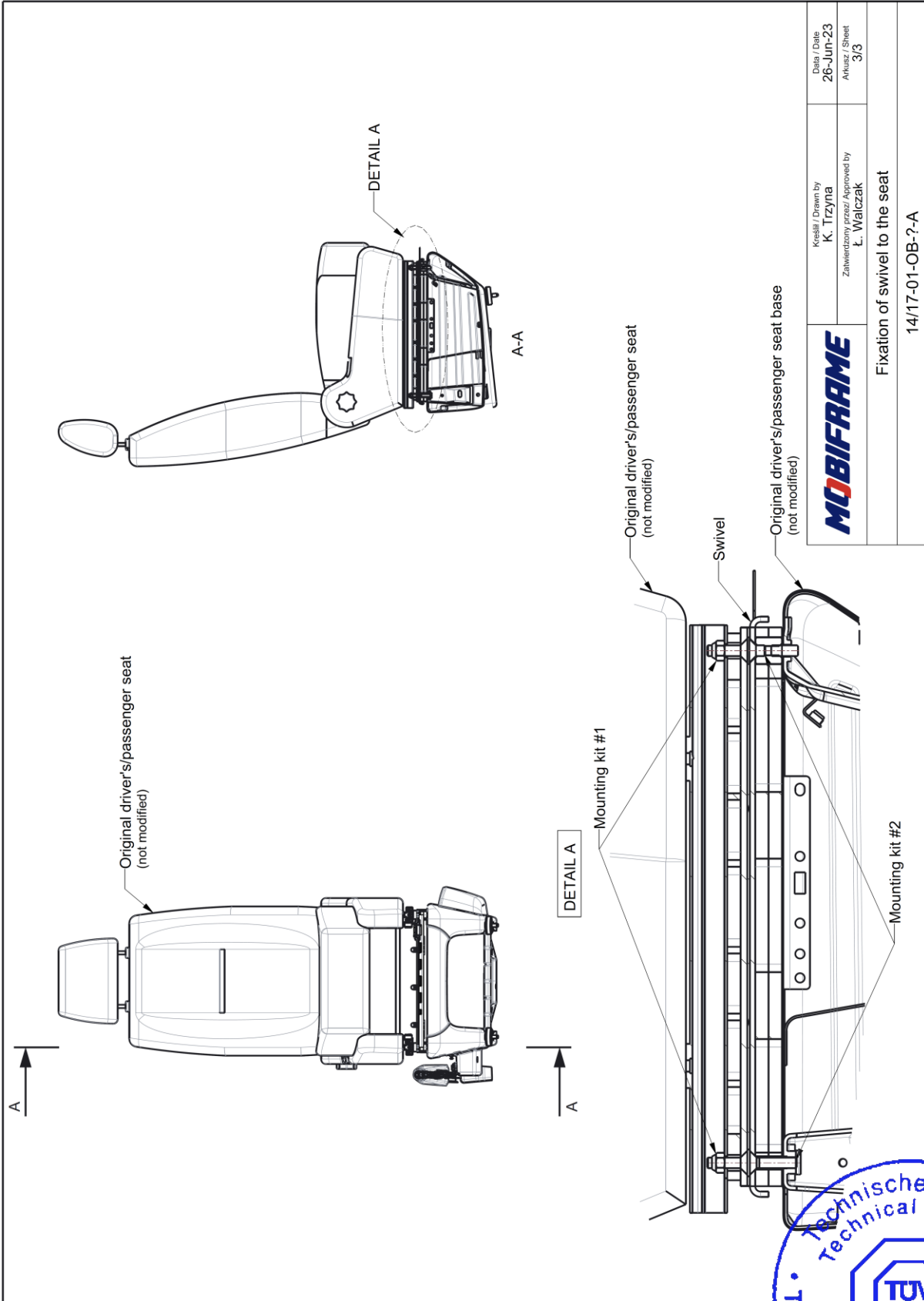

	Kresli / Drawn by K. Trzyna	Data / Date 26-Jun-23
	Zatwierdzony przez / Approved by L. Walczak	Arkusz / Sheet 3/3
Fixation of swivel to the seat 14/17-01-OB-?-A		

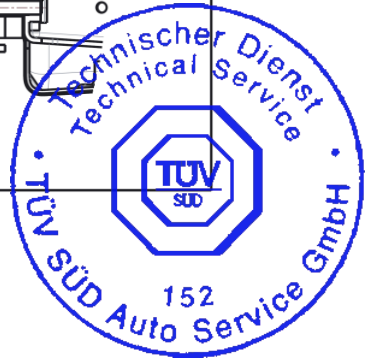

	Date: 26.06.2023
MOBIFRAME/02/2022-01	Page / pages: 12/29

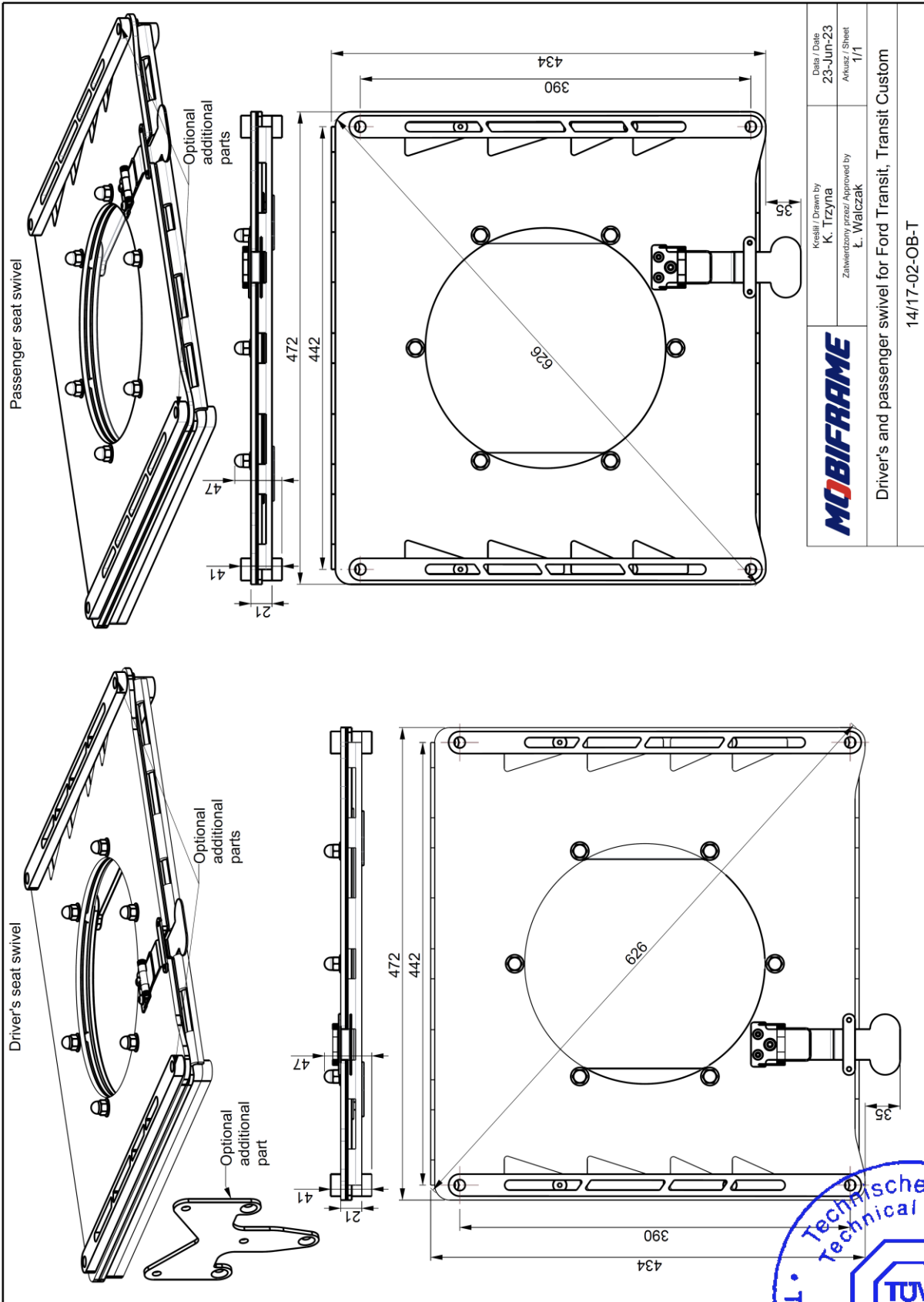

	Kresli / Drawn by K. Trzyna	Data / Date 23-Jun-23
	Zatwierdzony przez / Approved by L. Walczak	Arkusz / Sheet 1/1
Driver's and passenger swivel for Ford Transit, Transit Custom		
14/17-02-0B-T		

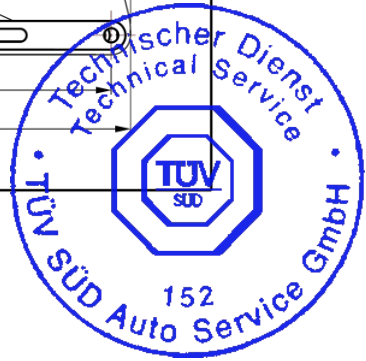

		Date: 26.06.2023
	MOBIFRAME/02/2022-01	Page / pages: 13/29

Passenger seat swivel

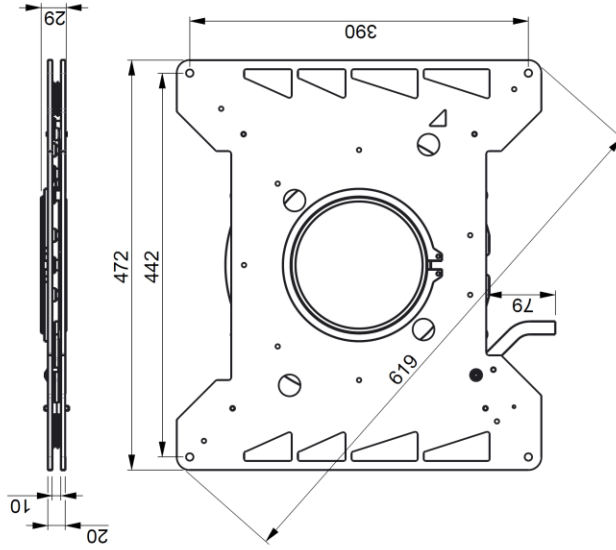
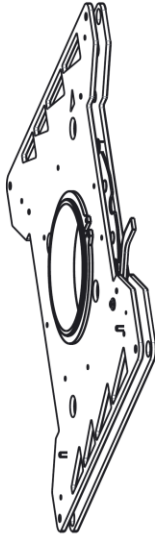

Driver's seat swivel

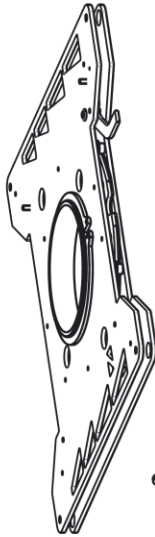

Optional additional part

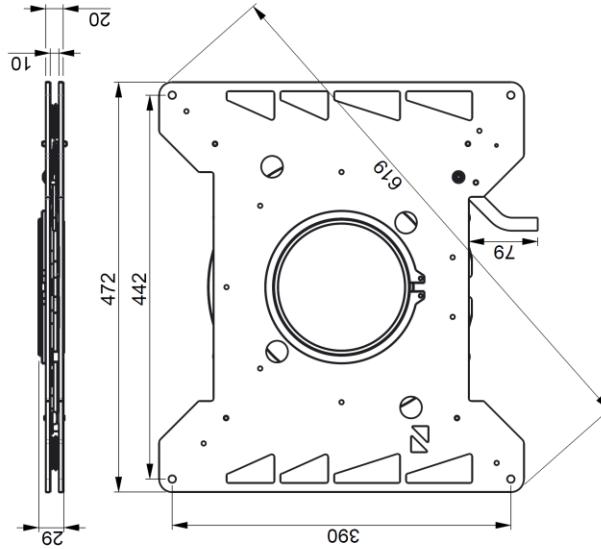

Kresli / Drawn by
K. Trzyna
Zatwierdzony przez / Approved by
L. Walczak

Data / Date
08-Jul-22
Arkusz / Sheet
1/1

Driver's and passenger swivel for Ford Transit, Transit Custom

14/17-02-0B-T

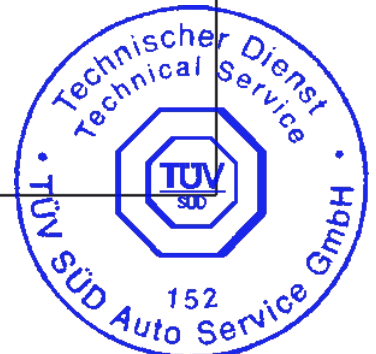

		Date: 26.06.2023
	MOBIFRAME/02/2022-01	Page / pages: 14/29

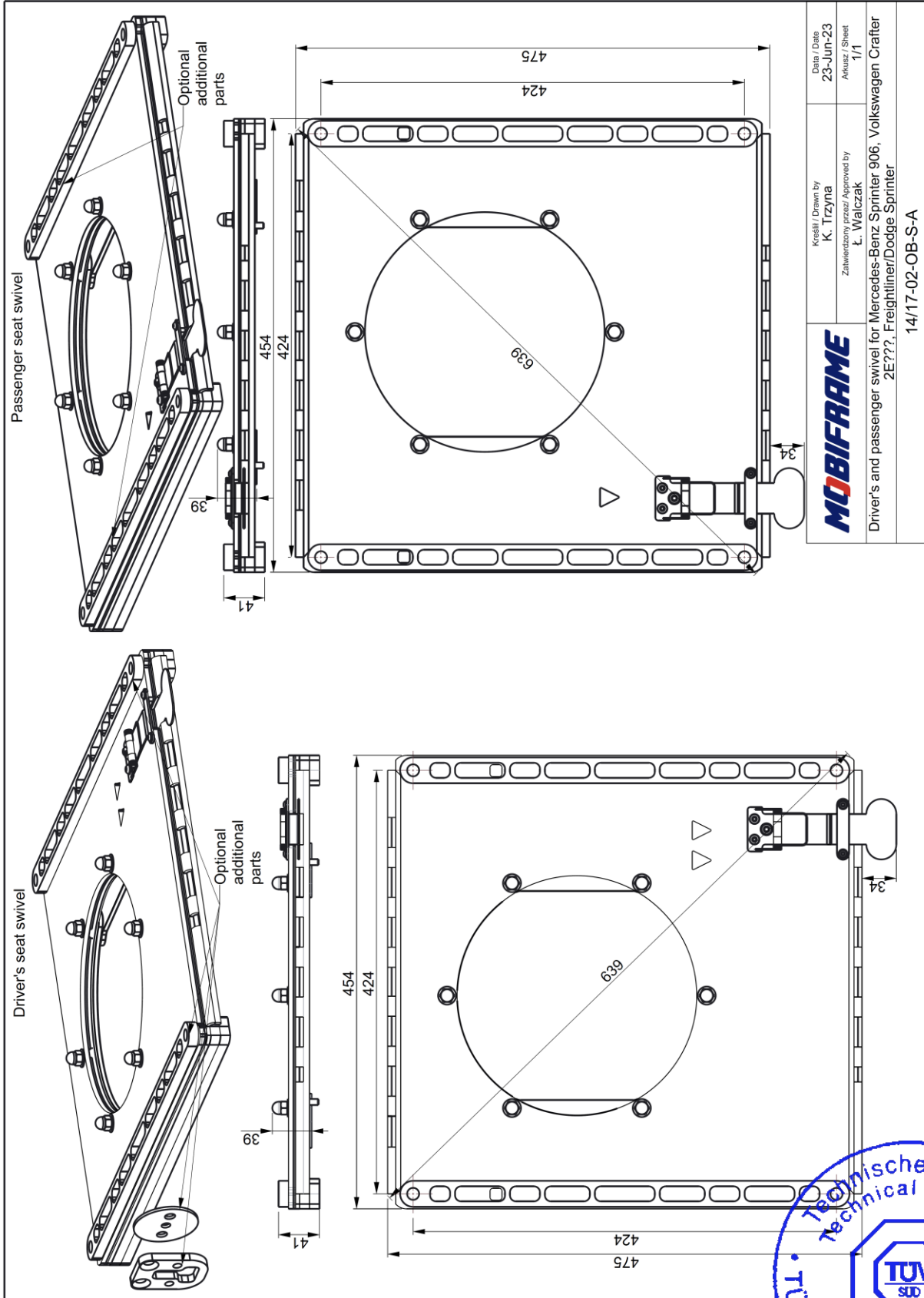

	Kreslil / Drawn by K. Trzyna	Data / Date 23-Jun-23
	Zatwierdzony przez / Approved by L. Walczak	Aktualiz. / Sheet 1/1
Driver's and passenger swivel for Mercedes-Benz Sprinter 906, Volkswagen Crafter 2E???, Freightliner/Dodge Sprinter		
14/17-02-OB-S-A		

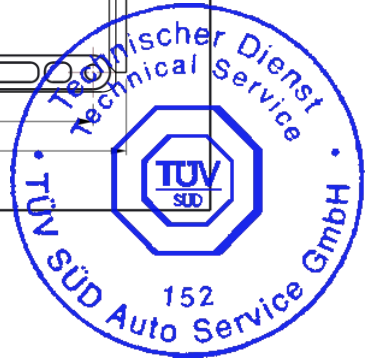

		Date: 26.06.2023
	MOBIFRAME/02/2022-01	Page / pages: 15/29

Passenger seat swivel

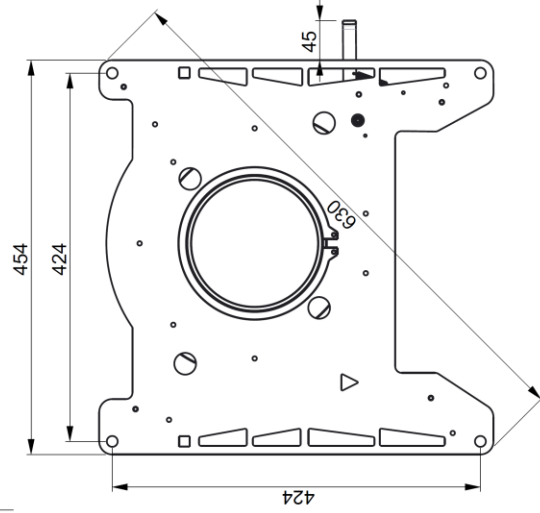
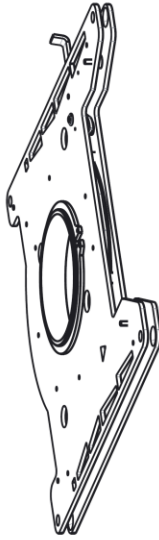

Driver's seat swivel

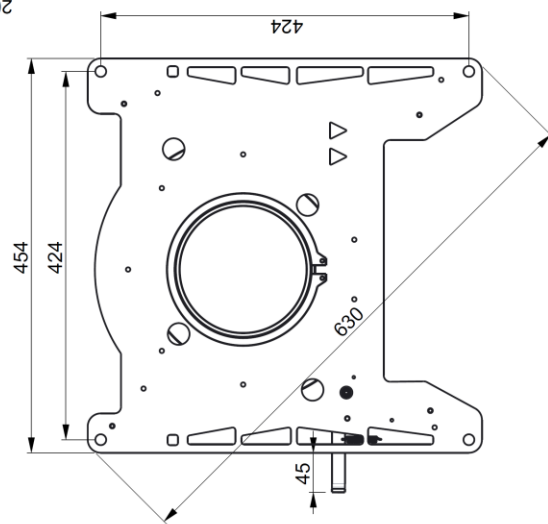
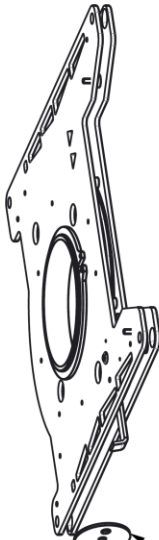

Optional additional parts



Kreslił / Drawn by
K. Trzyna
Zatwierdzony przez / Approved by
L. Walczak

Data / Date
08-Jul-22
Arkusz / Sheet
1/1

Driver's and passenger swivel for Mercedes-Benz Sprinter 906,
Volkswagen Crafter 2E???, Freightliner/Dodge Sprinter

14/17-02-OB-S

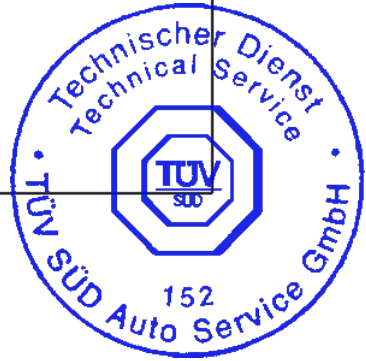

	Date: 26.06.2023
MOBIFRAME/02/2022-01	Page / pages: 16/29

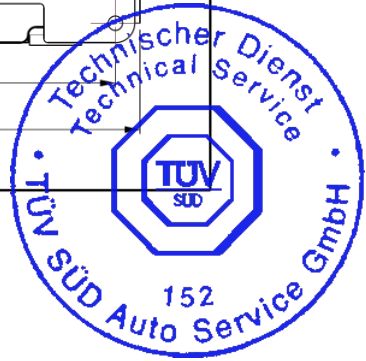
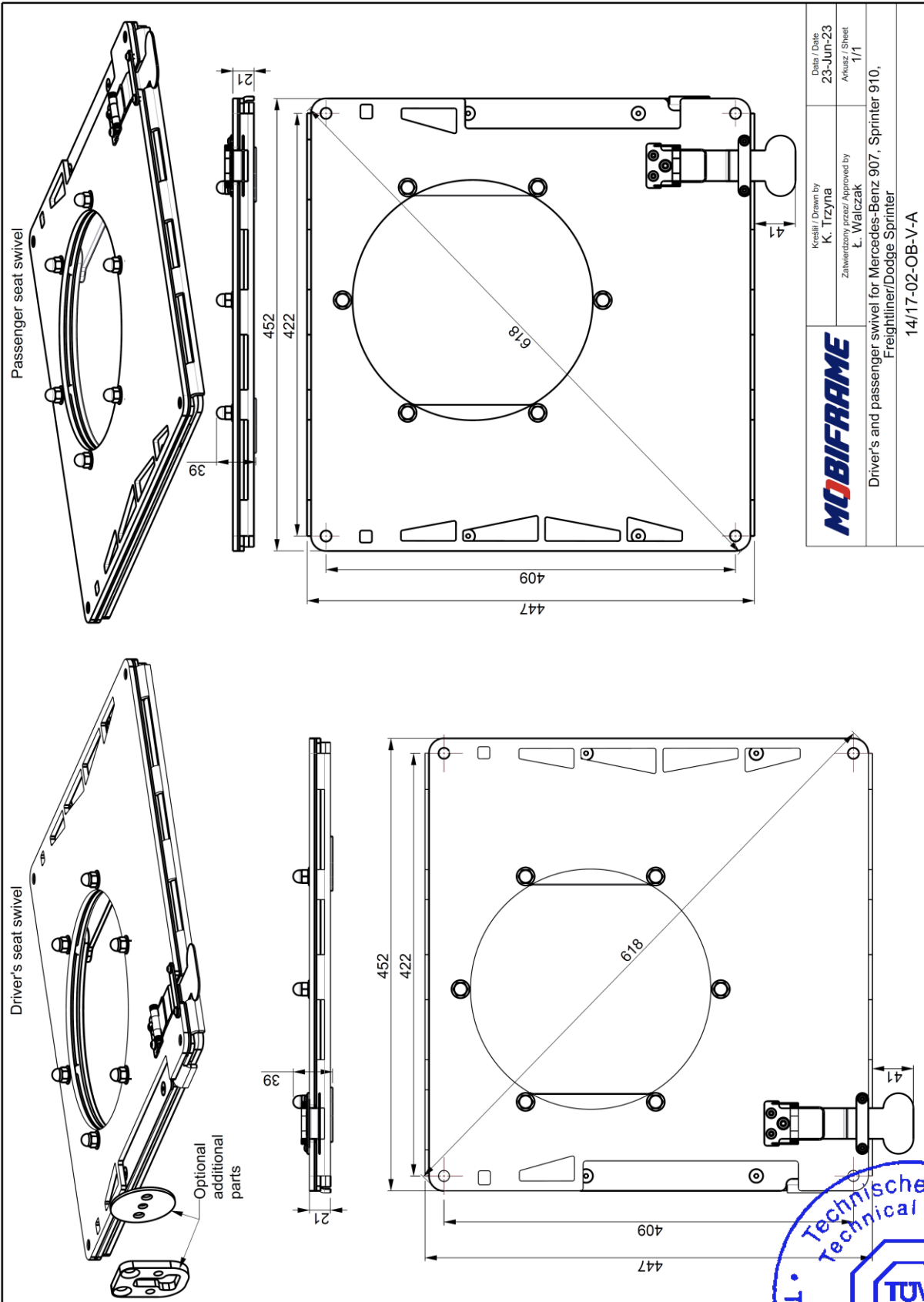

	Date: 26.06.2023
MOBIFRAME/02/2022-01	Page / pages: 17/29

Passenger seat swivel

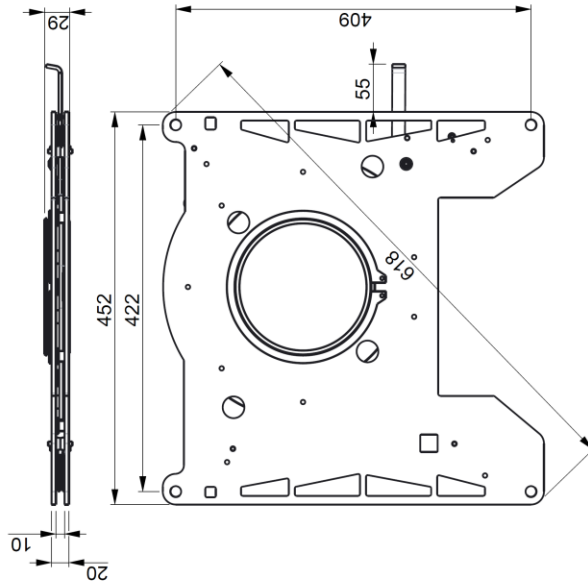
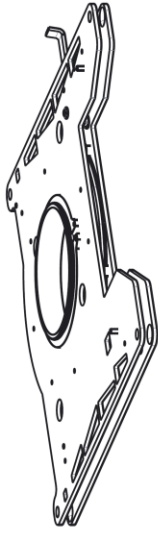

Driver's seat swivel

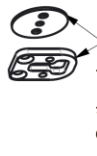
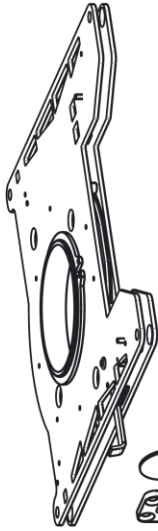

Optional additional parts

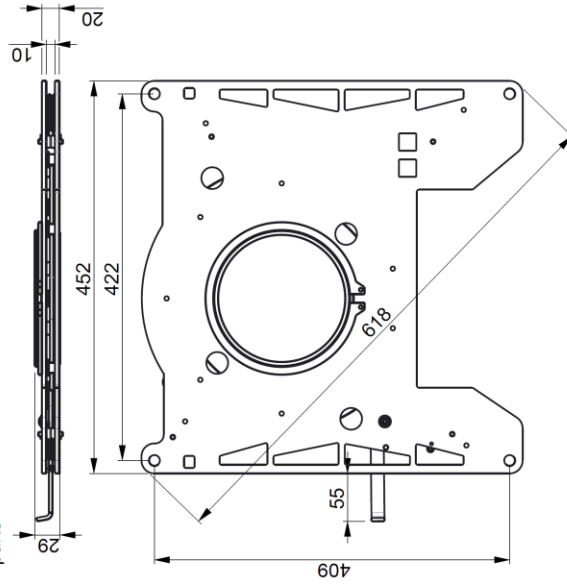

Kreslił / Drawn by
K. Trzyna
Zatwierdzony przez / Approved by
L. Walczak

Data / Date
08-Jul-22
Arkusz / Sheet
1/1

Driver's and passenger swivel for Mercedes-Benz Sprinter 910,
Freightliner/Dodge Sprinter
14/17-02-0B-V

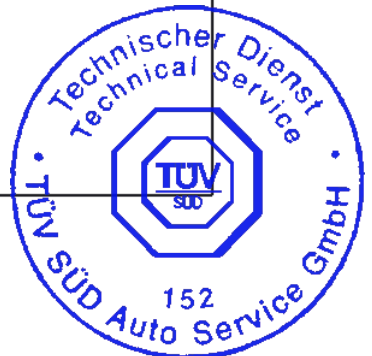

	Date: 26.06.2023
MOBIFRAME/02/2022-01	Page / pages: 18/29

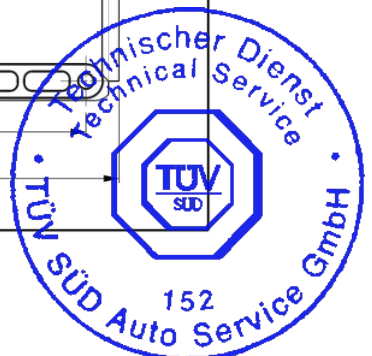
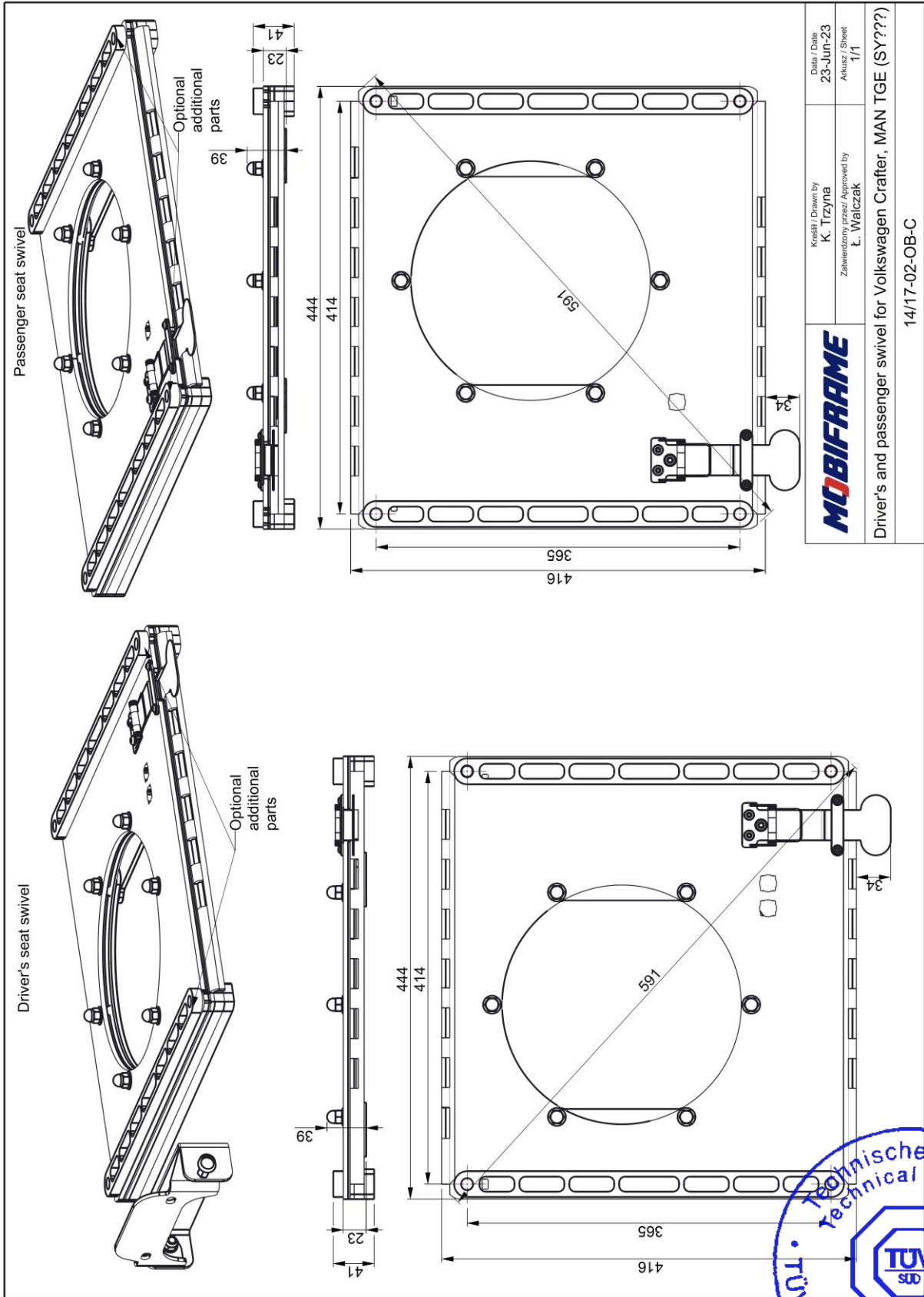

		Date: 26.06.2023
	MOBIFRAME/02/2022-01	Page / pages: 19/29

Passenger seat swivel

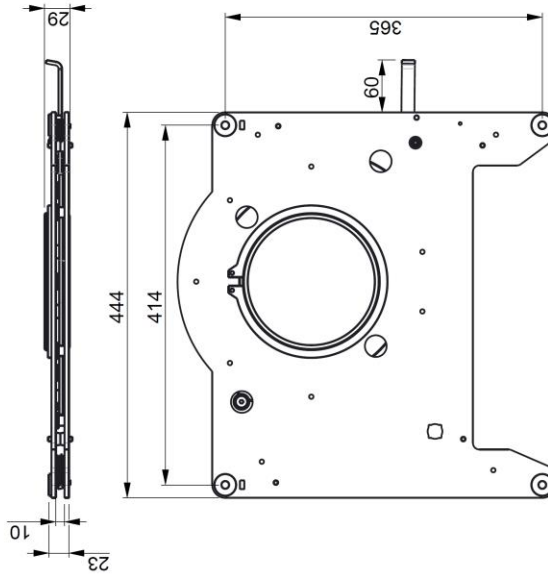
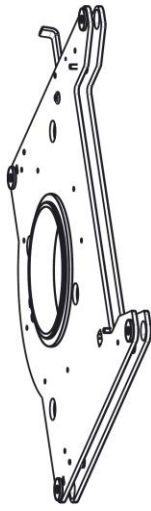

Driver's seat swivel

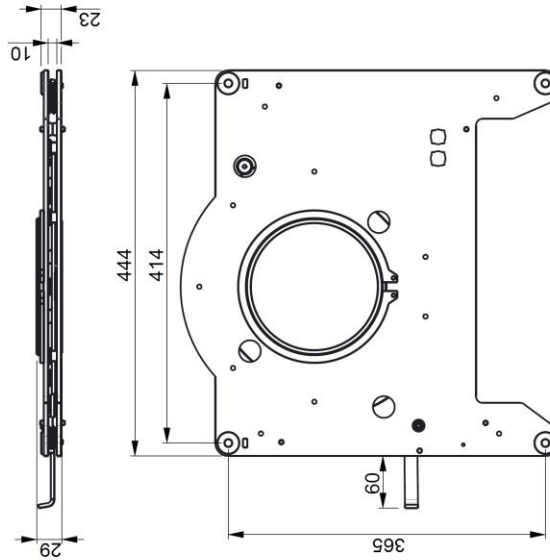
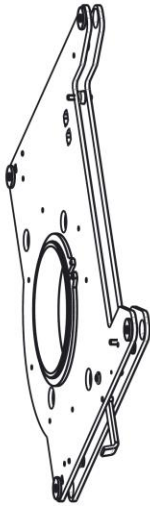

MOBIFRAME

Kresła / Drawn by
K. Trzyna
Zatwierdzony przez / Approved by
L. Walczak

Data / Date
08-Jul-22
Arkusz / Sheet
1/1

Driver's and passenger swivel for Volkswagen Crafter, MAN TGE (SY???)

14/17-02-OB-C

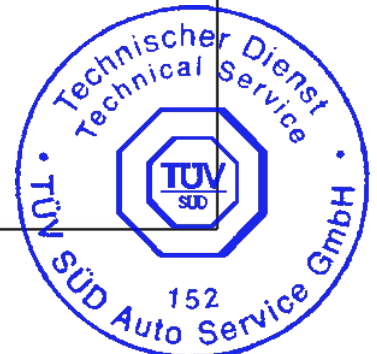

		Date: 26.06.2023
	MOBIFRAME/02/2022-01	Page / pages: 20/29

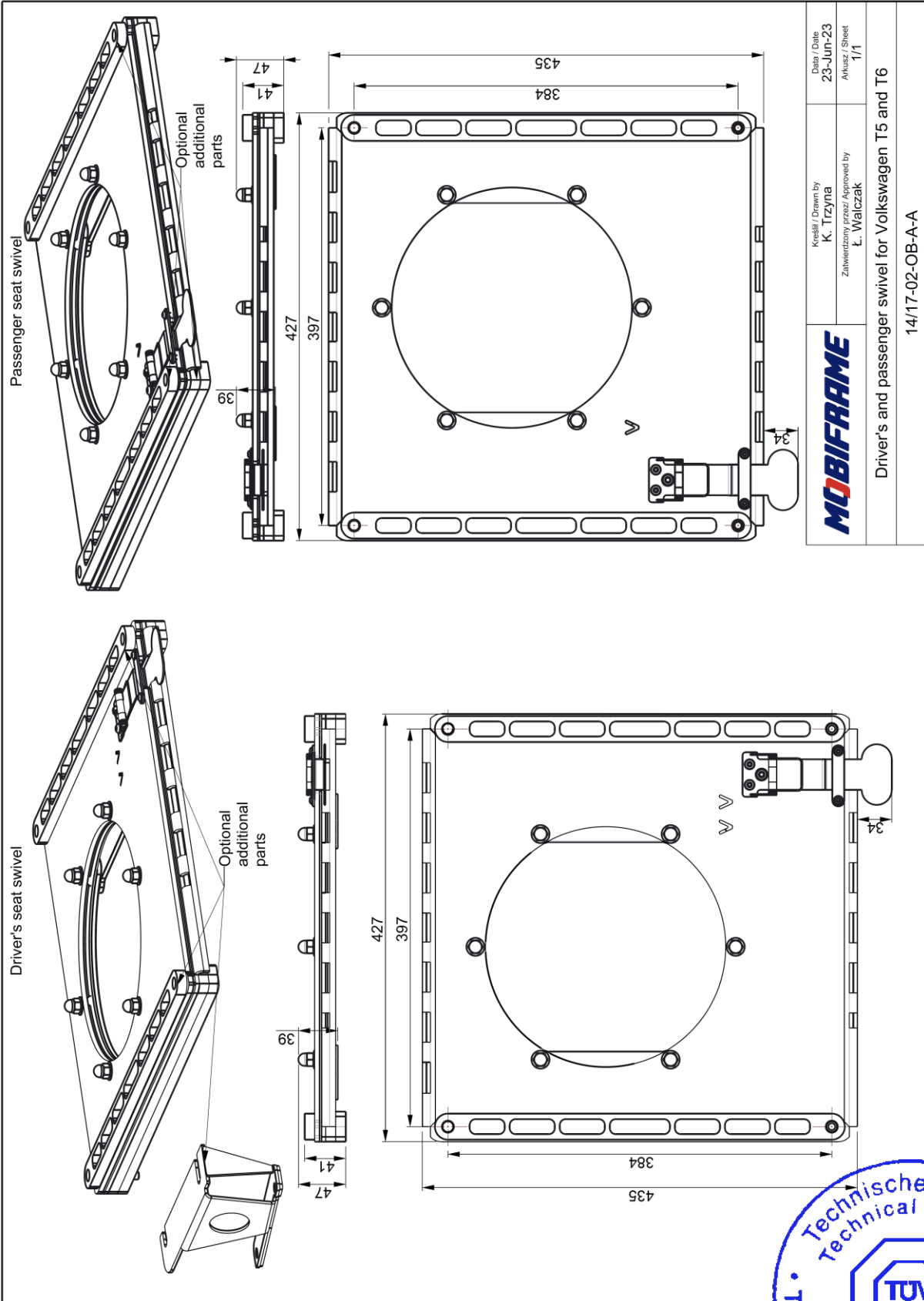

	Kresli / Drawn by K. Trzyna	Data / Date 23-Jun-23
	Zatwierdzony przez / Approved by L. Walczak	Arkusz / Sheet 1/1
Driver's and passenger swivel for Volkswagen T5 and T6		
14/17-02-OB-A-A		

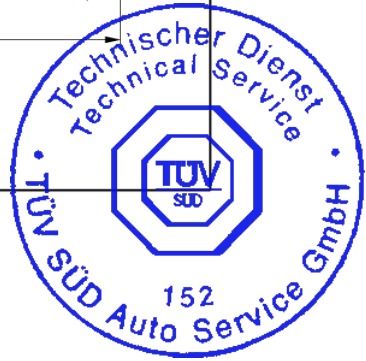

	Date: 26.06.2023
MOBIFRAME/02/2022-01	Page / pages: 21/29

Passenger seat swivel

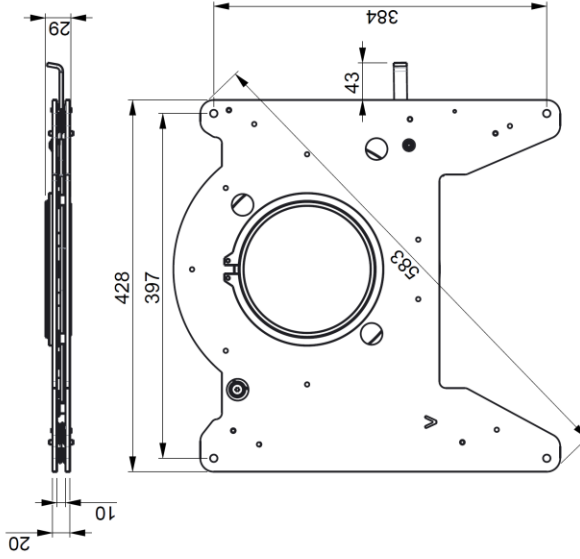
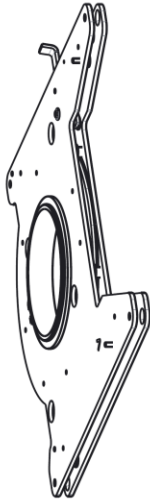

Driver's seat swivel

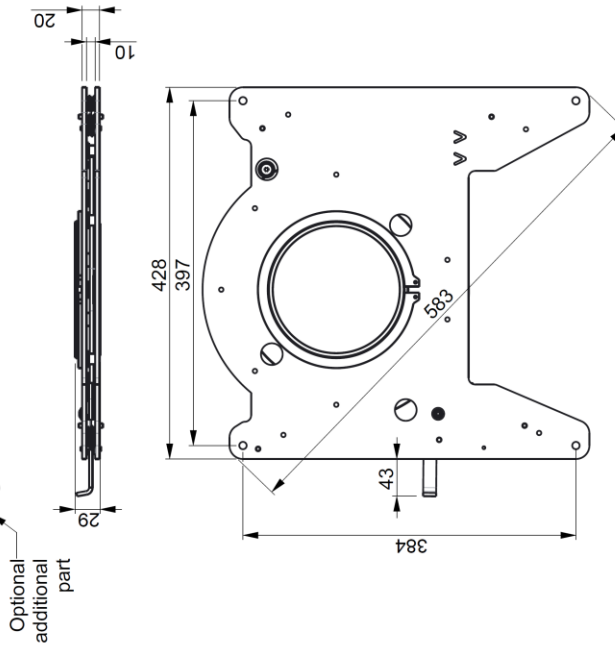
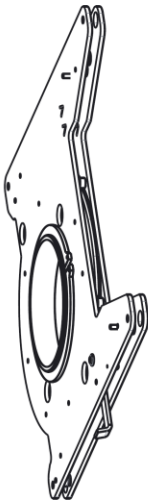

MOBIFRAME

Kresli / Drawn by
K. Trzyna
Zatwierdzony przez / Approved by
L. Walczak

Data / Date
08-Jul-22
Arkusz / Sheet
1/1

Driver's ans passenger swivel for Volkswagen T5 and T6

14/17-02-0B-A

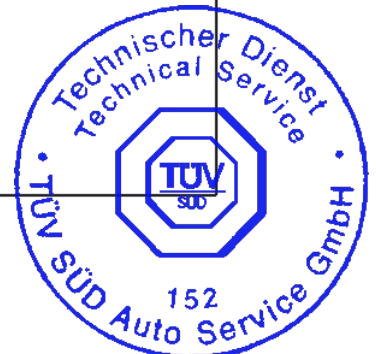

		Date: 26.06.2023
	MOBIFRAME/02/2022-01	Page / pages: 22/29

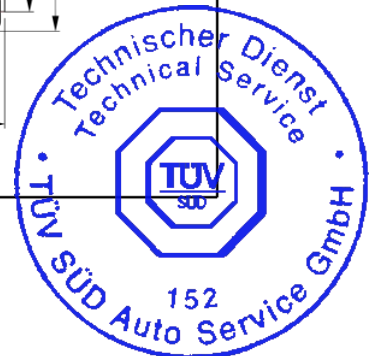
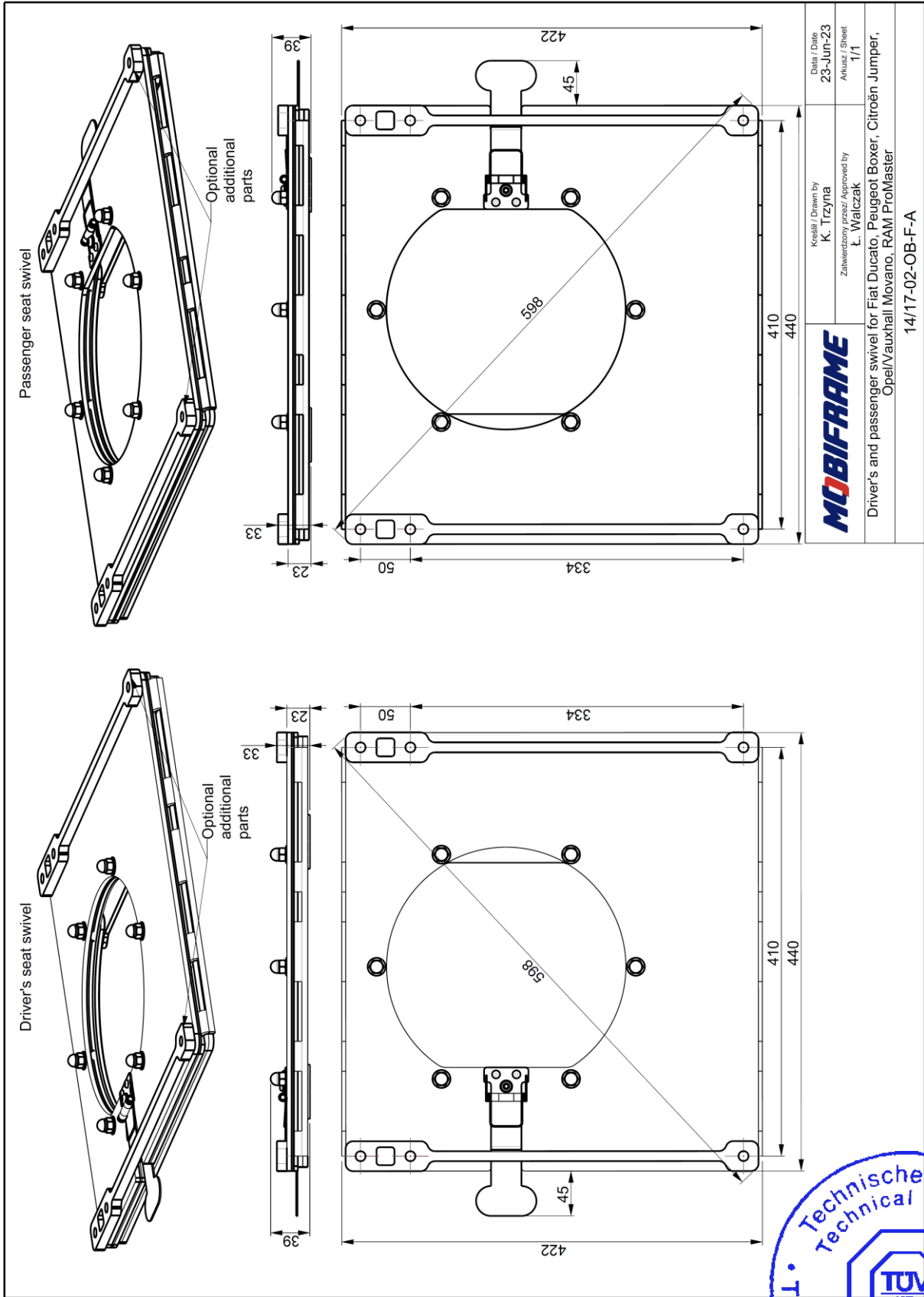

		Date: 26.06.2023
	MOBIFRAME/02/2022-01	Page / pages: 23/29

Passenger seat swivel

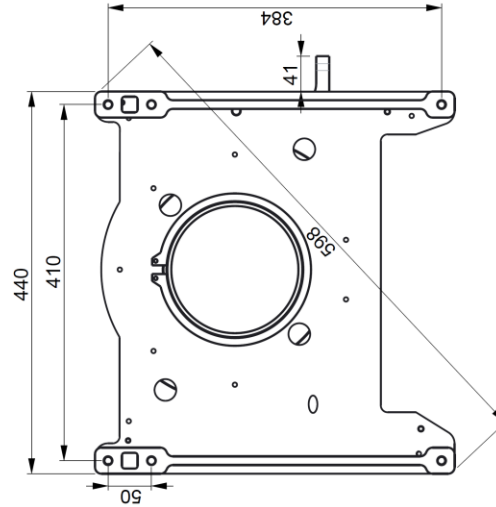
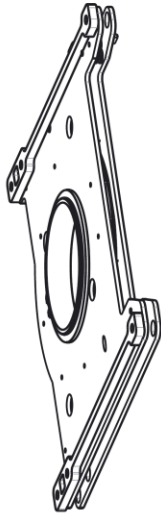

Driver's seat swivel

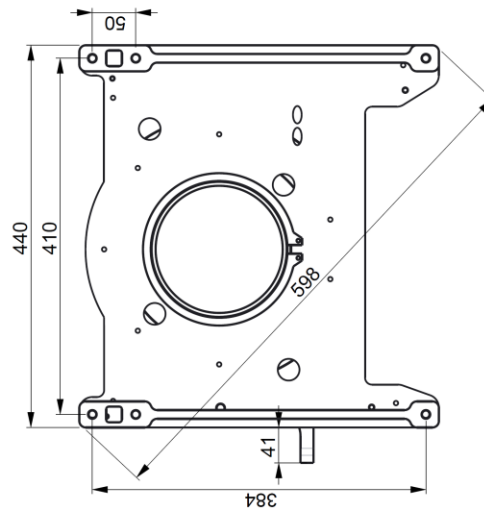
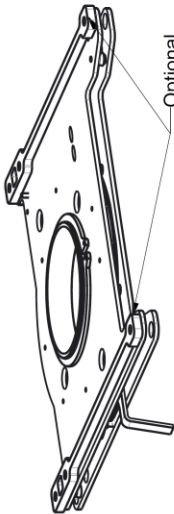

MOBIFRAME

Kresili / Drawn by
K. Trzyna
Zatwierdzony przez / Approved by
L. Walczak

Data / Date
08-Jul-22
Arkusz / Sheet
1/1

Driver's and passenger swivel for Fiat Ducato, Peugeot Boxer, Citroën Jumper,
Opel/Vauxhall Movano, RAM ProMaster

14/17-02-OB-F

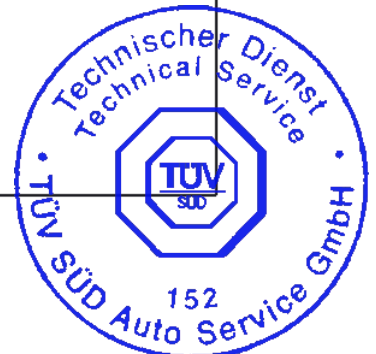

		Date: 26.06.2023
	MOBIFRAME/02/2022-01	Page / pages: 24/29

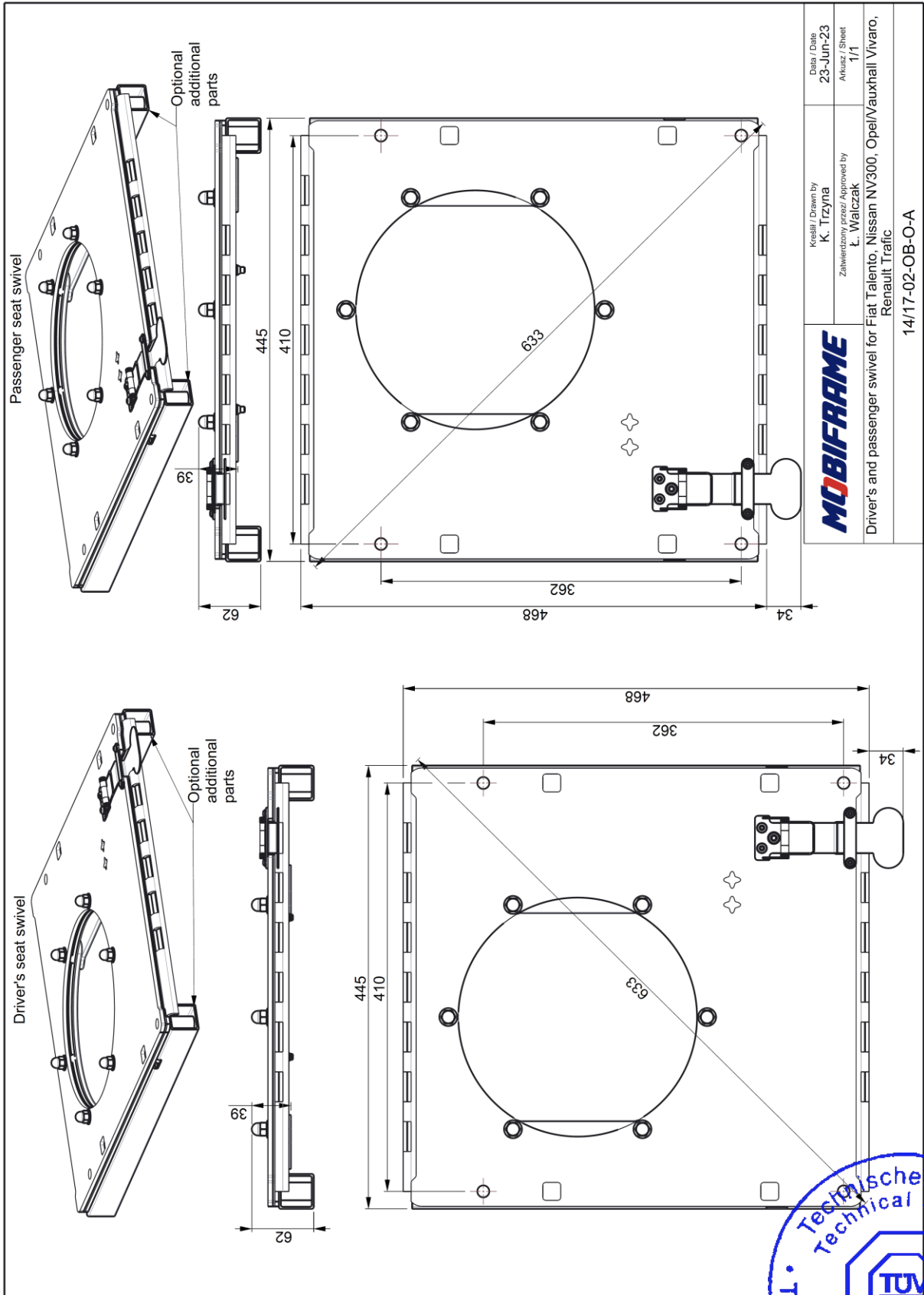

	Kresła / Drawn by K. Trzyna	Data / Date 23-Jun-23
	Zatwierdzony przez / Approved by Ł. Walczak	Arkusz / Sheet 1/1
Drivers and passenger swivel for Fiat Talento, Nissan NV300, Opel/Vauxhall Vivaro, Renault Traffic		14/17-02-OB-O-A

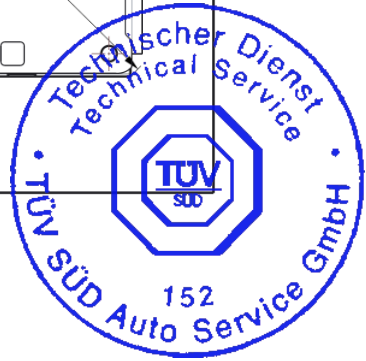

	Date: 26.06.2023
MOBIFRAME/02/2022-01	Page / pages: 25/29

Passenger seat swivel

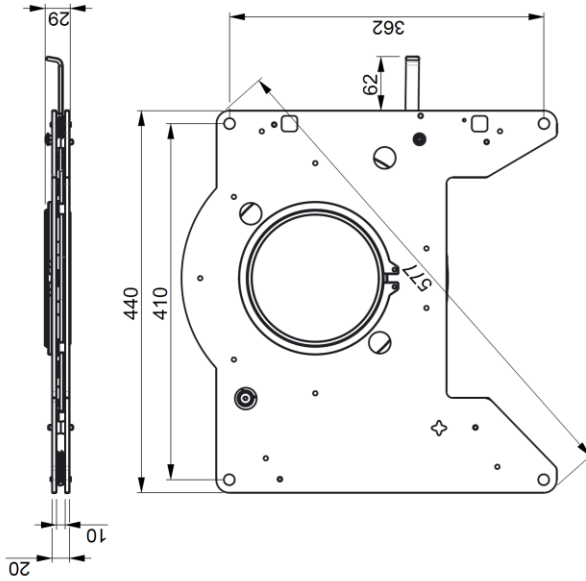
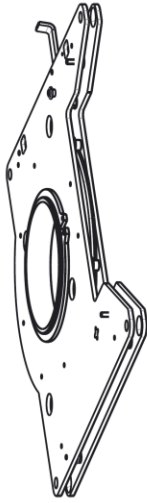

Driver's seat swivel

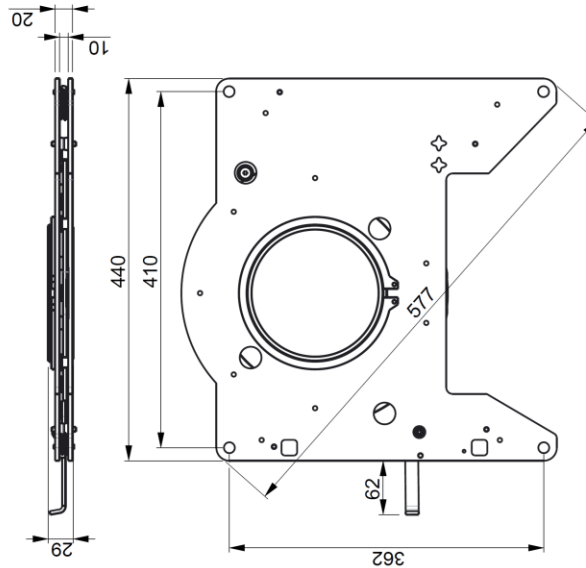
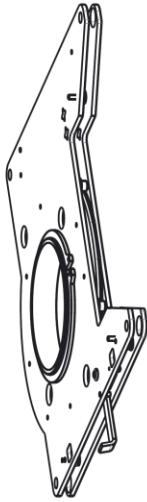

MOBIFRAME

Kresili / Drawn by
K. Trzyna
Zatwierdzony przez / Approved by
L. Walczak

Data / Date
08-Jul-22
Arkusz / Sheet
1/1

Driver's ans passenger swivel for Renault Traffic, Opel/Vauxhall Vivaro,
Fiat Talento, Nissan NV300

14/17-02-OB-0

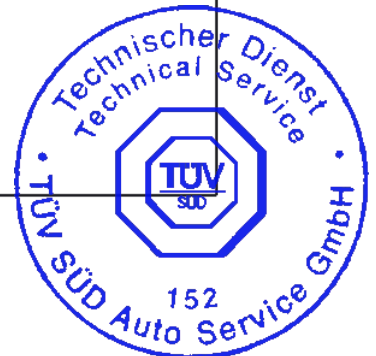

		Date: 26.06.2023
	MOBIFRAME/02/2022-01	Page / pages: 26/29

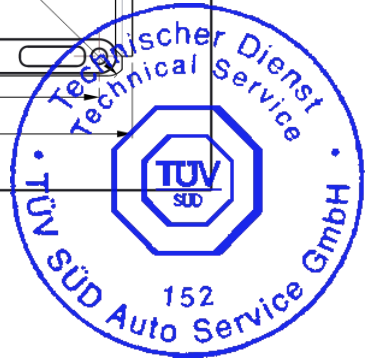
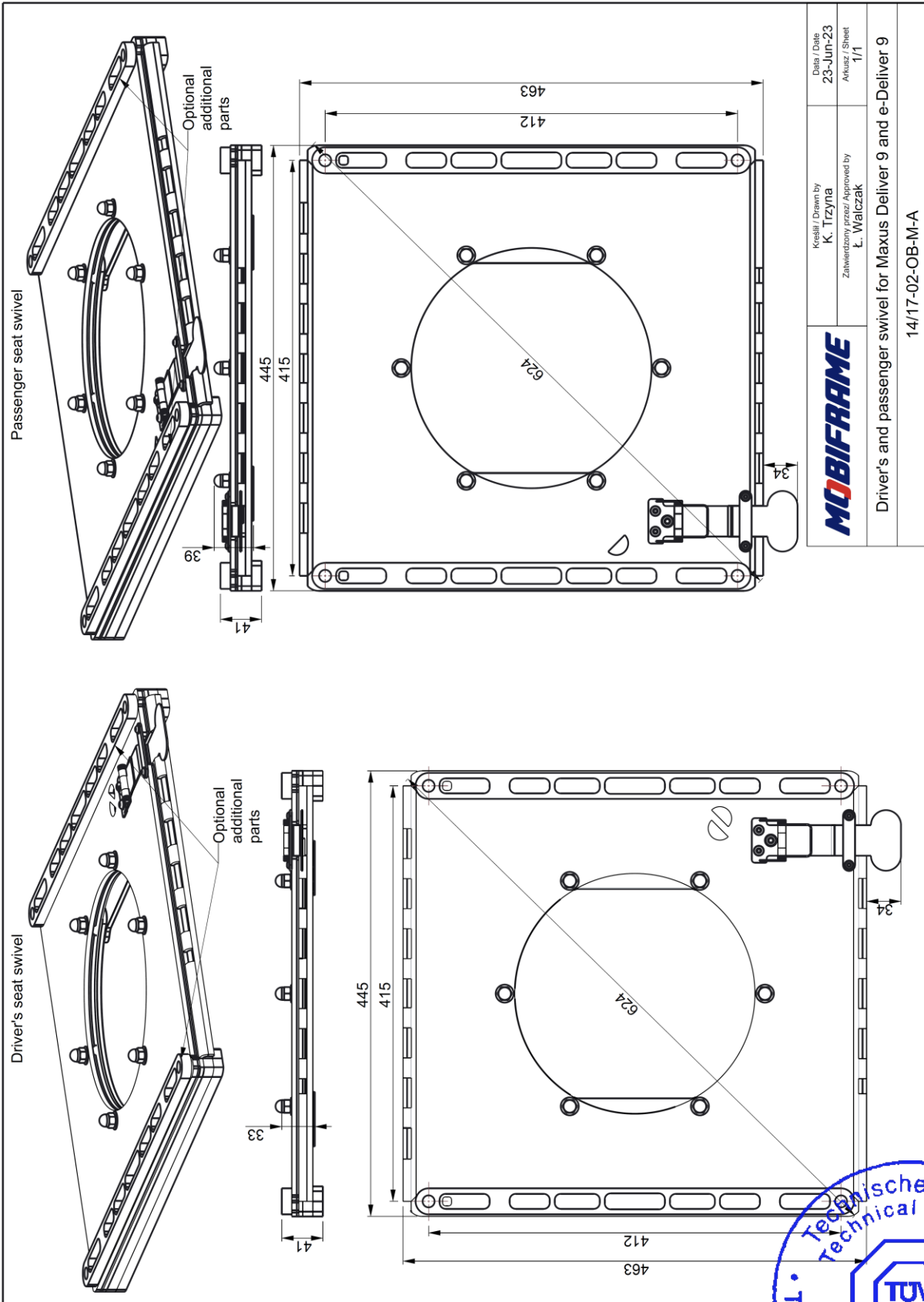

	Date: 26.06.2023
MOBIFRAME/02/2022-01	Page / pages: 27/29

Passenger seat swivel

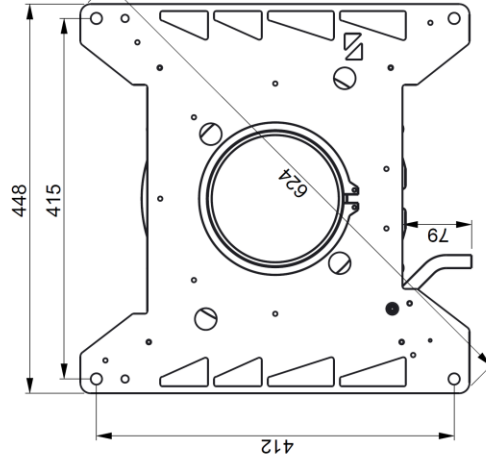
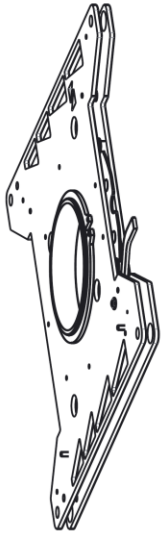

Driver's seat swivel

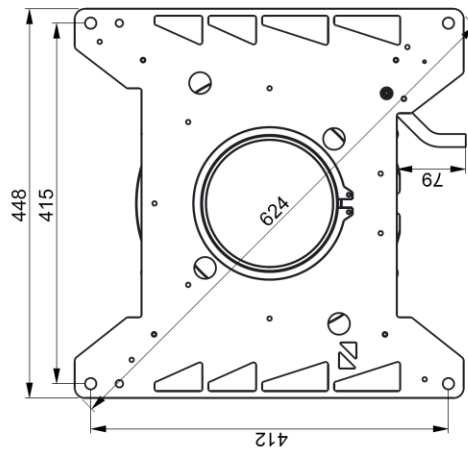
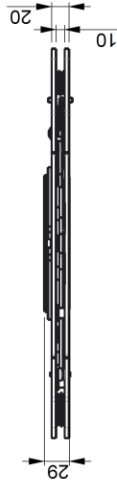
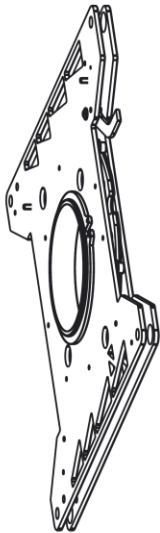

Kresła / Drawn by
K. Trzyna
Zatwierdzony przez / Approved by
Ł. Walczak

Data / Date
08-Jul-22
Arkusz / Sheet
1/1

Driver's and passenger swivel for Maxus eDeliver 9 and Maxus Deliver 9

14/17-02-OB-M

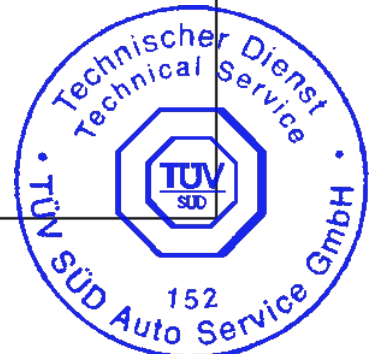

		Date: 26.06.2023
	MOBIFRAME/02/2022-01	Page / pages: 28/29

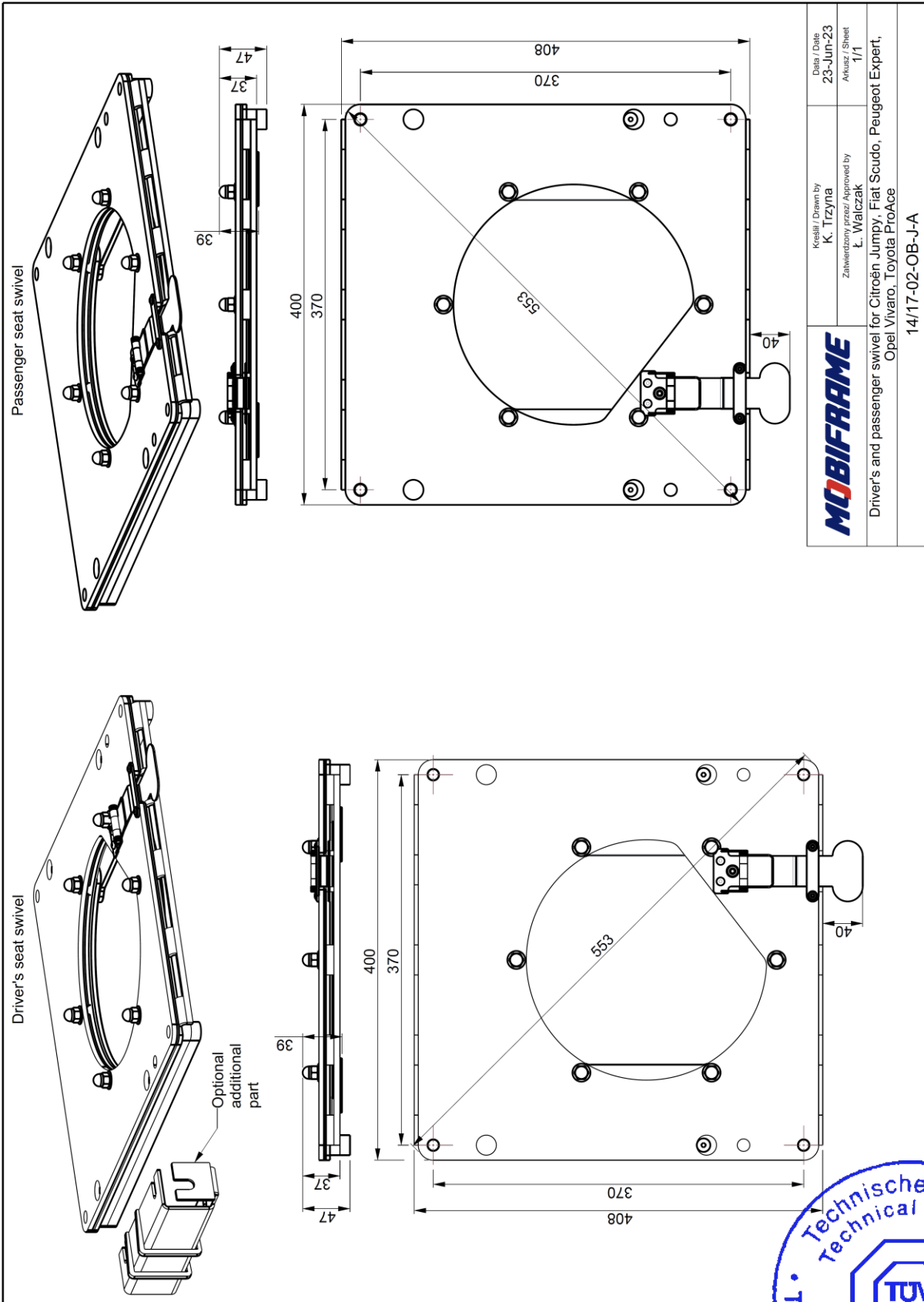

	Kresli / Drawn by K. Trzyna	Data / Date 23-Jun-23
	Zatwierdzony przez / Approved by L. Walczak	Arkusz / Sheet 1/1
Driver's and passenger swivel for Citroën Jumpy, Fiat Scudo, Peugeot Expert, Opel Vivaro, Toyota ProAce		
14/17-02-OB-J-A		

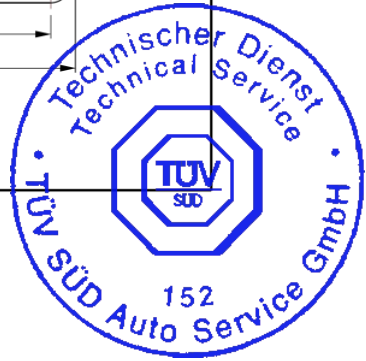

		Date: 26.06.2023
	MOBIFRAME/02/2022-01	Page / pages: 29/29